



## **Optimal Switching of Micro-grid Distributed Management based on Equilibrium Models**

**Ebadollah Amouzad Mahdiraji <sup>1\*</sup>**

<sup>1</sup> Department of Engineering, Sari Branch, Islamic Azad University, Sari, Iran.

Received: 09-Apr-2020, Revised: 03-May-2020, Accepted: 27-May-2020.

### **Abstract**

Optimal switching has been proposed as a tool to improve the utility of the electricity grid among researchers in the electricity industry. In fact, according to Kirchhoff's rules, the restriction of the transmission of power from one path entails restrictions on the power passing through the corresponding parallel paths. Thus, in some operating conditions, opening a transmission line reduces the parallel paths and constraints imposed and, consequently, improves the network operating conditions. The effects of micro switching on market power in the power system are discussed first. To this end, the competition boundary problem has been developed to consider micro-switching. In this problem, the application of linear-integer models obtained on test networks shows that micro-switching can affect market power in a power system. This effect is further enhanced by the increase in HHI. Also, this effect is even greater at high load levels. This indicates the undesirable effect of micro-grid switching on market power if used without regard to market power. The following is a model for optimizing the micro-network periodic switching as a tool for system deployment to reduce the periodic cost of network deployment considering the market power of the actors. The results show that the optimal periodic switching of the microprocessor can reduce the operating costs of the whole period by considering the market power of the actors. Also, it reduces the market power of the actors compared to the case of micro-grid switching.

**Keywords:** Switching, Market, Linear Optimization Problem, Equilibrium in Electricity Market.

### **1. INTRODUCTION**

---

\*Corresponding Authors Email:  
ebad.amouzad@gmail.com

In general, the exit or entry of micro-grid lines in the power grid is referred to the micro-grid transmission switching (TS). This switch can be forced or optional. Past research has shown that TS can be used as a control method to solve network problems.

Much of the focus of this research has been on providing a correct mechanism for resolving problems such as overload and voltage deviation from the specified range. A review of how to use TS as a suitable mechanism for response events has been done [1]. In an algorithm, TS is proposed to prioritize lines for overload control [2]. Based on the optimal power distribution, a suitable mechanism for using TS in the face of network problems has been introduced [3]. TS has been investigated by considering AC power playback for overloading lines in [4]. He has modeled a suitable mechanism for determining network control tools such as TS with continuous variables and binary variables. A quick mechanism for using TS in response to network events is presented. The advantage of this method over previous work is that it can change the grid arrangement and the amount of generator output, but in the earlier methods, the generator output was considered constant [5-7]. A review of the work done and the models proposed for TS and the methods for solving these models have been done [8]. Following the previous work, a suitable control mechanism for dealing with overload lines and voltage deviations from the specified range and methods for achieving the best response are both presented. The difference between this method and previous methods is the use of a new technique, including the inverse slimming technique and the fast separation technique to reduce the number of iterations needed to obtain the best response [9]. A method is proposed to obtain the best solution based on a binary variable for grid lines. In this method, when the voltage level is high, it is assumed that the operators are

aware of a line that has a low impact on reliability at all times and can disconnect it from the grid for voltage problems [10]. TS has also been used as a tool to minimize the losses of energy grid lines in [11], [12] and congestion management in [13]. There are also examples in the industry of TS application to improve voltage profiles and microcontroller capacity such as [14-15]. What is at stake in the research reviewed in this section is that the TS is carried out only when the technical issues of power system operation (including security and reliability) require a switch.

In the restructured environment of the electricity industry, increasing the efficiency and competitiveness of the market is crucial. One way to achieve this is to reduce the amount of market power that is directly related to the layout of the network. Changing the layout of the network can affect market power. Therefore, the impact of TS on market power, which has not been explored before, is addressed in this paper. According to optimization theory, if there is enough time to solve the problem, it is possible to achieve global optimality. But the problem of HHI maximization lacks this feature. To solve this problem and to get rid of computational problems, we will approximate the objective function in linear form. In this way, the Extended Competition Boundary Problem (ECB) will be transformed into the MILP form, which under any circumstances (minimization and maximization) is sure to find the absolute optimal answer. After modeling, the minimum and maximum HHI values in the desired network are tested and measured and their sensitivity to electricity

market parameters and linearization parameters are investigated.

## 2. INTRODUCING THE MAIN FUNCTIONS

Energy management at the total cost of energy and the system reserve is considered as the objective function over the intended

$$\text{System Cost} = \sum_{t=1}^T \left\{ \begin{array}{l} \left[ \begin{array}{l} F^{\min}(i) \times u(i,t) + \sum_{msf=1}^{NSF} sl(i,msf) \times p(i,t,msf) \\ + y(i,t) \times SUC(i) + z(i,t) \times SDC(i) \\ + Q_g^{up}(i,t) \times R_g^{up}(i,t) + Q_g^{dn}(i,t) \times R_g^{dn}(i,t) \end{array} \right] \\ + \sum_{j=1}^{Nd} Q_d^{up}(j,t) \times R_d^{up}(j,t) + Q_d^{dn}(j,t) \times R_d^{dn}(j,t) + IC(j,t) \times ILS(j,t) \end{array} \right\} \quad (1)$$

In relation to (1),  $i$  unit number layout from 1 to  $N_g$ ,  $j$  bus number index from 1 to  $N_d$ ,  $msf$  single cost function hunting index from 1 to  $NSF$ ,  $t$  time index from 1 to  $T$ ,  $F^{\min}$  lowest production cost,  $u(i,t)$  unit brightness indicator,  $sl(i,msf)$  slope related to each of the linearized pieces is a unit cost function,  $p(i,t,msf)$  the output corresponds to each unit cost function,  $Z$  and  $Y$  indicate the unit on and off,  $SUC$  and  $SDC$  the cost of setting up and turning off each unit.  $R_g^{up}(i,t)$  and  $R_g^{dn}$  the upward and downward reservation rate of production,  $R_d^{up}$  and  $R_d^{dn}$  the upward and downward

time of the operator and the operator will seek to manage this issue, this cost function is shown in relation (1). The unit bid function is linear and the quotation quotes are also available from the reservation providers. In this objective function, only thermal units are considered. To see how modeling can be used to reference, other production costs [16-19] are presented:

reserve rate,  $Q$  is the rates offered for different reservations. Furthermore,  $ILS$  denotes the involuntary amputation rate and  $IC$  represents involuntary amputation price rate. Therefore, the aim is to find the lowest cost (proposed price) of power plant production by determining unit management and production capacity of each of them taking into account unit and network constraints. As we know, the power cost functions of the various units are nonlinear and are usually represented by a quadratic function. But if we want to apply them in the same way as in the optimization problem, a nonlinear problem with real numbers is obtained, which is impossible to solve in these dimensions. To do this, the proposed unit price relationship is written as follows:

$$0 \leq p(i,t,msf) \leq p_g^{\max}(i,msf) \times u(i,t) \quad (2)$$

$$p_g(i,t) = p_g^{\min}(i,t) \times u(i,t) + p(i,t,1) + \dots + p(i,t,msf) \quad (3)$$

$p_g(i,t)$  the unit power,  $p_g^{\min}(i,t)$  the lowest unit power, and  $p_g^{\max}(i,msf)$  the maximum power is in that unit. Since the bid price function is a monotonous function, the graph slope always increases, so that the cost of production of each part of the cost function reaches its maximum before the next part and then the next section begins to fill. The power reserve is powered by synchronous generators that can be used within 10 minutes. Non-refundable reservation is actually an unmanaged production capacity that can be used within 10 minutes [17-19]. Each unit that is designated as a reservation supplier after executing the unit deployment plan receives a designated reserve price for the reservation. If reserved for any reason at the time of operation, this reservation will be

$$\sum_{i=1}^{Ng} outg(i,t) \times [p_g(i,t) + R_g^{up}(i,t,k) - R_g^{dn}(i,t,k)]$$

$$= \sum_{j=1}^{Nd} [p_d(i,t) - R_d^{up}(j,t,k) + R_d^{dn}(j,t,k) - ILS(j,t,k)] \quad \forall t, k \quad (5)$$

$k$  index of probable event number,  $p_d$  denotes power consumption per bus, and  $outg$  denotes unit output. Each unit, if it is switched on, will have a minimum and maximum power output, and the maximum and minimum power outputs of the units will be modeled with respect to the amount of reserve provided by them.

$$p_g(i,t) - p_g(i,t-1) \leq (1 - y(i,t)) \times RU(i) + y(i,t) \times p_g^{\min}(i)$$

$$p_g(i,t) - p_g(i,t-1) \leq (1 - z(i,t)) \times RD(i) + z(i,t) \times p_g^{\min}(i) \quad \forall t \quad (7)$$

charged based on the instantaneous price of that bus [20-22].

### 3. THE CONSTRAINTS ON THE MAIN RESEARCH PROBLEM

This section addresses the various constraints used in the main issue. The power supply (power balance) constraints of the system at baseline (prior to the occurrence of probable events) and after the occurrence of probable events are presented in Equations (4) and (5), respectively. The power output of power plants and the power consumption of loads must be equal. In this problem load distribution is used to reduce the problem-solving time, thus eliminating transmission line losses in the power relation [23-25].

$$\sum_{i=1}^{Ng} p_g(i,t) = \sum_{j=1}^{Nd} p_d(j,t) \quad \forall t \quad (4)$$

$$p_g(i,t) + R_g^{up}(i,t) \leq p_g^{\max}(i) \times u(i,t)$$

$$p_g(i,t) - R_g^{dn}(i,t) \geq p_g^{\min}(i) \times u(i,t) \quad \forall i, t \quad (6)$$

$p_g^{\max}$  is the maximum output power per unit. Each unit has a limited ability to increase and decrease power in one hour, depending on its type and size, and the limitation on the change in power output during different hours is shown in (7):

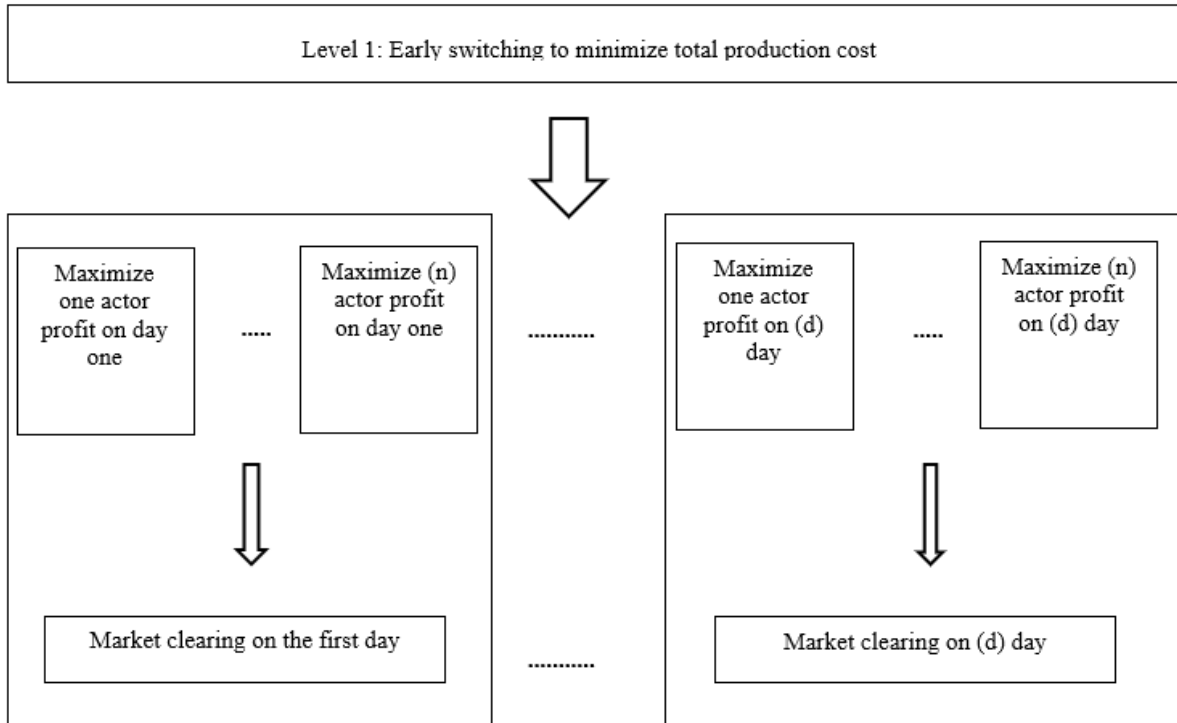

**Fig. 1. The structure studied.**

$RU$  and  $RD$  are the rates of increase and decrease in the output power of each unit. As can be seen in Figure 7, if we did not have the unit switched on at time  $t$ , the maximum allowable increase would be the same, but if the generator was switched on, it would certainly produce the minimum unit clear at the first hour.

#### 4. MODELING THE DESIRED SYSTEM

In this case, at the first level, the decision is made to switch a line for the whole period at the beginning of the period. This is aimed at minimizing the cost of production during the period by considering the balance between the actors. At the second and third levels of the three-level problem, the behavior of actors in the electricity market is modeled. These two levels of problems are repeated for each day of the course in question. The second level problem is the maximization of

the profit of the actor (owner of production units) bound by the same actor and the third level problem of the market settlement problem. Figure (1) shows the general scheme of this structure. The third-level optimization problem illustrates the mechanism of market settlement by the market operator (MO), so that the MO minimizes the operating cost of one day of the period by constraining the network utilization constraint. The second level and the third level are related to each other because the bid price of the producers affects the prices and the amount of production (the third level) and also the amount of production and the prices affect the profits of each player (the second level). The balance between players in the market will also affect the first level of the issue and the first level switch will affect the balance between the players.

### 5. LEVEL 1 ISSUE: MINIMIZING THE COST OF OPERATING THE ENTIRE COURSE

The first level issue is the decision to switch lines to reduce the operating cost of the whole period. The objective function of this problem is to minimize the cost of operating the entire network over a period. The general form of this problem is as follows:

$$\text{Min } \sum_d \sum_g \alpha_{g,d} p_{g,d} \quad (8)$$

subject to:

$$\sum_l (1 - n_l) \leq NL^{\max} \quad (9)$$

In the above equations, the variables  $\alpha_{g,d}, p_{g,d}$  are the generating power and the bid price of the generator  $g$  for day  $d$ ,  $n_l$  being

$$\text{Max } \sum_g (AOG_{j,g} \sum_n ANG_{g,n} (\lambda_{n,d} p_{g,d} - \text{Cost}_g p_{g,d})) \quad (10)$$

subject to:

$$AOG_{j,g} \alpha_{g,d} \geq 0 \quad : \forall g, j = k, \forall d = m \quad (11)$$

In this respect  $\lambda_{n,d}$  represents the price in bus  $n$  on day  $d$  and  $\text{Cost}_g$  represents the final cost of generator  $g$ . In relation (10), the profit of each generator is given by the difference in revenue ( $ANG_{g,n} \lambda_{n,d} p_{g,d}$ ) and production cost ( $\text{Cost}_g p_{g,d}$ ). The intersection matrix of the sheen and the generator set the price for the generators. For example, if generator 1 is located in bus 1, only the value of  $ANG_{g_1, n_1}$  considered for it is 1, so the price of bus 1 is calculated for it, and the price of another bus in the calculation of profit for generator 1 is involved. Relation (11) shows that the price

the binary variable to represent the state of the line  $l$  during the period and  $NL^{\max}$  denotes the number of lines allowed to switch. The latter is determined by the system operator. Since an excessive increase in the number of lines allowed for switching does not increase the cost savings, therefore, some are considered to have no adverse effect on system reliability over time and the optimized number.

### 6. LEVEL 2: MAXIMIZING ACTOR PROFIT

In the second level of the issue, the actors bid to maximize their profits. The problem of maximizing actor profits ( $k$ ) per day ( $m$ ) of the period in question is as follows:

offered by the owner of generators should be positive.

### 7. LEVEL THREE: THE MARKET CLEARING PROBLEM

The market settlement problem is an optimization problem with the aim of minimizing the cost of network operation that is used in the third level of the problem. Here is the problem of market-clearing on the day of ( $m$ ). Note that this problem is unique for all actors and only runs once per day considering the actor's bid price:

$$\text{Min} \sum_g \alpha_{g,d} p_{g,d} \quad (12)$$

subject to:

$$-\pi \leq \delta_{n,d} \leq \pi : \forall n \setminus \text{reference bus}, \forall d = m \quad (13)$$

$$P_g^{\min} \leq p_{g,d} \leq P_g^{\max} : \forall g, \forall d = m \quad (14)$$

$$-P_l^{\max} n_l \leq p_{l,d} \leq P_l^{\max} n_l : \forall l, \forall d = m \quad (15)$$

$$-\sum_l ALN_{l,n} p_{l,d} + \sum_g ANG_{g,n} p_{g,d} - D_{n,d} = 0 : \forall n, \forall d = m \quad (16)$$

$$\sum_n ALN_{l,n} B_l \delta_{n,d} - p_{l,d} + M_l(1 - n_l) \geq 0 : \forall l, \forall d = m \quad (17)$$

$$\sum_n ALN_{l,n} B_l \delta_{n,d} - p_{l,d} - M_l(1 - n_l) \leq 0 : \forall l, \forall d = m \quad (18)$$

$$\delta_{n,d} = 0 : \forall n = \text{reference bus}, \forall d = m \quad (19)$$

## 8. REPLACING THE OBJECTIVE FUNCTION WITH A LINEAR EXPRESSION

To linearize the expression  $\sum_g \alpha_{g,d} p_{g,d}$  in the objective function, we first replace it with the second side of strong duality:

$$\begin{aligned} \sum_d \sum_g \alpha_{g,d} p_{g,d} &= \sum_d \sum_{n \setminus \text{ref.}} (\xi_{n,d}^{\text{down}} + \xi_{n,d}^{\text{up}})(-\pi) + \sum_d \sum_g \mu_{g,d}^{\text{down}} P_g^{\min} \\ &+ \sum_d \sum_g \mu_{g,d}^{\text{up}} (-P_g^{\max}) \\ &+ \sum_l (\vartheta_{l,d}^{\text{down}} + \vartheta_{l,d}^{\text{up}})(-P_l^{\max} n_l) + \sum_d \sum_n \lambda_{n,d} D_{n,d} \\ &+ \sum_l \sum (\beta_{l,d}^{\text{down}} + \beta_{l,d}^{\text{up}})(-M_l(1 - n_l)) \end{aligned} \quad (20)$$

In the upper right of the relation, there are two nonlinear expressions that are the product of two variables, one of which is binary. The following technique is used to replace them with linear relationships:

$$\text{if } Xz = Y \quad (21)$$

$$-M^X(1 - z) \leq X - Y \leq M^X(1 - z) \quad (22)$$

$$-M^X z \leq Y \leq M^X z \quad (23)$$

In the above relation  $X$  is a continuous variable,  $z$  is a binary variable and  $M^X$  is a

large enough positive number. It is assumed that the product of these two variables is equal to the  $Y$  variable. If the binary variable has a value of 1, then the variable  $Y$  will be the same as the variable  $X$ , and the range  $Y$  will be the range of the variable  $X$ . The range of variable  $X$  is denoted by a sufficiently large number  $M^X$ . If the binary variable has a value of zero, then the variable  $Y$  will also be zero, and the variable  $X$  may have a non-zero value in the range specified by  $M^X$ .

## 9. INTRODUCING THE THREE BUSES TEST NETWORK

In this section, the model is applied to a test network with three paths and the results are described. We will first analyze the obtained model for a day at the base load of the network to prove the model's validity and evaluate it for arbitrary value for  $\zeta_{j,d}$ . We then investigate the sensitivity of the problem to  $\zeta_{j,d}$  and apply the proposed model to

obtain different balance in the network. After evaluating the effects of  $\zeta_{j,d}$  on the results, we apply the model to the test network over some time and compare the results with the actors offering their final price on the network. In this section, a three buses test network are selected and introduced to analyze the market balance and the effect of optimal periodic switching on it. The network has three buses, three generators, three micro-lines, and one load. Also, Figure 2 shows the linear diagram of the three buses network. Tables (1) and (2) show the bus information and 3-bus network lines, respectively.

Table (3) shows the results for full competition conditions. As it is clear from the table information, in full market competition, without considering the optimal periodic switch, the network operating cost is 63259.025 \$/h. In this case, the total profit for all owners was 1500 \$/h all day.

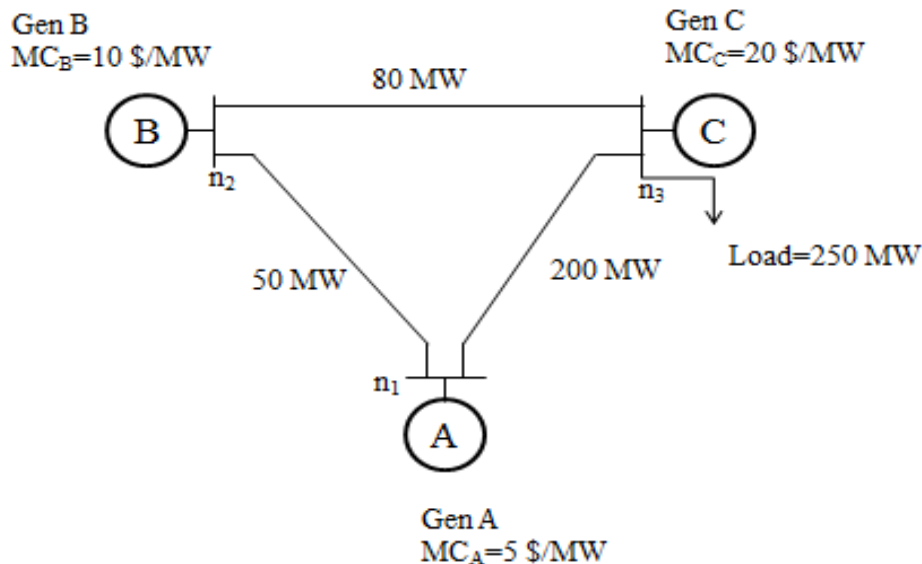

Fig. 2. Linear diagram of the three buses network.



**Table 1. Three buses network information.**

Bus	Generator	The final cost of production (\$/MWh)	Load (MW)	Production capacity (MW)
n <sub>1</sub>	A	5	0	150
n <sub>2</sub>	B	10	0	80
n <sub>3</sub>	C	20	250	140

**Table 2. Three buses network lines information.**

Line	from bus	To bus	Impedance (pu)	Thermal limit (MW)
1	n <sub>1</sub>	n <sub>2</sub>	0.01	50
2	n <sub>2</sub>	n <sub>3</sub>	0.01	80
3	n <sub>3</sub>	n <sub>1</sub>	0.01	200

**Table 3. Three buses network results under full competition in one season.**

Status	total cost (\$/h)	Maximum total profit (\$/h-Day)	Maximum price in buses (\$/MWh)			Maximum generating capacity of generators (MWh/h-Day)		
			n <sub>1</sub>	n <sub>2</sub>	n <sub>3</sub>	A	B	C
Without TS	63259.025	1500	15	10	20	150	45	117.5
Considering the optimal TS	55031.587	2250	20	20	20	150	80	82.5

## 10. OVERALL COST OF ENERGY AND RESERVATION OF THE INTENDED SYSTEM

This section introduces the methodology and combines it with the conventional methods to consider the uncertainty of the aforementioned method in eliminating constraints and reducing the execution time of the program. In this part of the existing formulation is used, with the exception that in the part of the objective function obtained

for different scenarios, for each reserve unit corresponding to each scenario, the formula is replaced by the formulation and the additional constraints are eliminated. The corresponding function and constraints are shown below. The overall cost of energy and reservation of the system during the intended time of the operator is considered as the objective function as the energy cost depends on the amount of power produced and system reserves; the operator will seek to reduce this cost. That is, this cost function is shown in

relation (24) using the index  $k$  which indicates the probable event and, in this research, the index  $s$  is used instead of the index  $k$  representing scenario number  $1$  to  $N_s$ .

$$\text{System Cost} = \sum_{t=1}^T \left\{ \begin{aligned} & \left[ F^{\min}(i) \times u(i,t) + \sum_{msf=1}^{NSF} sl(i,msf) \times p(i,t,msf) \right. \\ & \left. + y(i,t) \times SUC(i) + z(i,t) \times SDC(i) \right. \\ & \left. + Q_g^{up}(i,t) \times R_g^{up}(i,t) + Q_g^{dn}(i,t) \times R_g^{dn}(i,t) \right] \\ & \left. + \sum_{j=1}^{Nd} Q_d^{up}(j,t) \times R_d^{up}(j,t) + Q_d^{dn}(j,t) \times R_d^{dn}(j,t) + IC(j,t) \times ILS(j,t) \right\} \end{aligned} \right. \quad (24)$$

$$+ \sum_{s=1}^{N_s} \pi_s \sum_{t=1}^T \sum_{j=1}^{Nd} \left\{ \begin{aligned} & [S_s(j,t) - W_s(j,t)] \times LMP(j,t) \times \left\{ \begin{aligned} & B_s(t) \times \delta_s(t) - (outg_s(t) \times BG_s \times P_g(i,t) -) \\ & P_d(j,t) + p_{wp,s}(t) \end{aligned} \right\} \\ & + p_{wp,s}(t) \times Q_{wp}(t) \end{aligned} \right\}$$

$\pi_s$  and  $p_{wp,s}$  respectively indicate the probability of occurrence and potential output in each scenario and ( $MLP$ ) the marginal price vector for each bus. Therefore, the aim is to find the lowest bid price of power plants by determining the management of the units and the production capacity of each of them considering the limitations of the units and the network and wind scenarios. The first line of the objective function represents the proposed unit production price. The second line includes the cost of turning the unit on and off. The third line includes the cost of up and down reservations on the production side. The fourth line includes the cost of downhill and uphill booking as well as the cost of disconnecting the load. The fifth line contains the cost associated with each scenario, which is the cost of the reservations used in each scenario, where  $S$  and  $W$  are obtained from the bass type sub-program. ( $S-W$ ) can be assigned values of  $1$  and  $-1$  when  $1$  requires upward reserve, i.e. the generator must

Obviously, variables and constants will, in essence, have the same role as before

receive the cost of this reserve or increase production, or the consumer must bear the cost of reducing load. Returns that must be added to the cost. ( $S-W$ ) If the downstream reservation needs to be made, the generator will receive less in return for reduced output, or the consumer will pay more for more consumption, which should be charged. The bottom line is the cost of producing a wind power plant when a cost is considered (in this study there is no cost involved). This paper assumes that wind producers are not competitive in the energy market ( $Q_{wp}(t) = 0$ ).

## 11. SIMULATION RESULTS

Table (4) shows the amount of energy purchased at each time interval. The bulk of the power demanded by the future contract is supplied to consumers at  $85\$$  per MWh, according to the demand-price curve, the retailer must meet 15% of consumer demand. For example, in the time and scenario, the

power demanded by consumers is 2MWh, of which 15%, 52.5MWh, must be provided by the retailer through the future contract and the subscription market. By importing the unit, the price offered to consumers is 75\$ per megawatt-hour, which means that the retailer will have to supply 35% of the demand through the futures contract, the common market and the unit of production. On the other hand, as the unit of production proposes a reduced selling price to consumers, purchases from the futures contract decrease and purchases from the subscription market increase (Table 4). While the cost of operating the unit is 110\$/MWh, it does not generate heat in two time 2 and 3 scenarios (Table 5).

Analysis of the simulation results shows that having a heat production unit increases the retailer's profit by 92.5%.

If the cost of a thermal power plant is also high (in this case it has changed from \$ 100 to \$ 110 a megawatt-hour), then the profit from the absence of a thermal power plant will increase and the risk will be reduced to 59.9% and 3.2%, respectively and reduces the offer price to consumers by 11.76%. Due to the reduced risk of importing heat generation units, the contractual power through the futures contract reduced and the purchase of energy from the subscription market increases. Therefore, the presence of a dispersed production unit is beneficial to both the retailer and the consumer.

## 12. CONCLUSION

Optimal switching of lines can significantly save costs as filling parts of the network will prevent the optimal distribution of cheaper

**Table 4. Purchased energy without heat generation unit (MWh).**

Scenario	First time interval		Second time interval	
	Subscription market	Future market	Subscription market	Future market
1	5.750	47.425	1.325	47.425
2	7.325	47.425	2.825	47.425
3	8.825	47.425	4.825	47.425
4	6.575	47.425	3.575	47.425

**Table 5. Energy purchased with thermal generation unit (MWh).**

Scenario	First time interval			Second time interval		
	Subscription market	Future market	Thermal unit	Subscription market	Future market	Thermal unit
1	47.842	15.908	50	56.596	15.908	50
2	51.342	15.908	50	61.844	15.908	50
3	54.842	15.908	50	65.342	15.908	50
4	53.093	15.908	50	60.092	15.908	50

production units. In this paper, the switching problem in the sample grid has been tested and validated. The use of Optimal Switching (MESOTS) has reduced costs by 24.4% by opening eleven lines. The use of a switch for the purpose of saving and complying with the MESOTS criterion resulted in cost savings by opening eleven lines of 8.6%. Adherence to the criterion has led to a reduction in savings while it increases overall cost. The MESOTS problem-solving time cannot be compared to the MESOTS problem since it solves only one line at a time, and is almost the same for each opened line. The solution is not optimal for the MESOTS problem and it takes much more time to solve this problem than the MESOTS problem. The MESOTS problem also ignored some events that did not answer the question. After identifying the impact of microcontroller switching on market power and the possibility of providing more market power about switching, the following article presents a model for optimal microcontroller switching periodically to reduce network operating costs by considering actors' market power. Generally, in an under-competitive market, system operating costs are higher than the full competition, and generator bids are higher. But it has been shown that the optimum periodic switching of the micro-grid reduces the bid price of the generators and brings their bid closer to their final cost. This reduces the total cost of operation and the ability of market players to exercise market power. Optimal Micro Network Periodic Switching tries to reduce prices on network paths by removing the line and then removing the line after casting the power distribution in such a way as to cast the least market power and

lower operating costs. It also minimizes the network. After optimizing the microprocessor switching periodically, the grid layout changes so that the cheaper generators -that are limited in production layout regardless of switching- can produce the equivalent of their full capacity in the new layout.

## REFERENCES

- [1] Q. Jiang, M. Xue, G. Geng, Energy management of micro grid in grid-connected and stand-alone modes. *IEEE Trans Power Syst*, No.28, pp. 3380–3389, 2013.
- [2] MH. Moradi, M. Abedini, SM. Hosseini, A combination of evolutionary algorithm and game theory for optimal location and operation of DG from DG owner standpoints. *IEEE Trans Smart Grid*, No. 7, pp. 608–616, 2016.
- [3] MH. Moradi, M. Abedini, SM. Hosseini, Improving operation constraints of micro grid using PHEVs and renewable energy sources. *Renew Energy*, No. 83, pp. 543–552, 2015.
- [4] AA. Moghaddam, A. Seifi, T. Niknam, MR. Alizadeh Pahlavani, Multi-objective operation management of a renewable MG with back-up micro turbine/fuel cell/battery hybrid power source. *Energy*, No. 36, 6490–6507, 2011.
- [5] A. Mondal, S. Misra, SL. Patel, KS. Pal, S. Mohammad, DEMANDS: Distributed Energy Management Using Noncooperative Scheduling in Smart Grid. *IEEE Systems Journal*, No. 12, pp. 2645-2653, 2018.
- [6] RD. Zimmerman, CE. Murillo-Sanchez, RJ. Thomas, Matpower:

- steady-state operations, planning, and analysis tool for power systems research and education. *IEEE Trans Power Syst*, No. 26, pp. 12-19, 2011.
- [7] M. Hemmati, S. Ghasemzadeh, B. Mohammadi-Ivatloo, "Optimal scheduling of smart reconfigurable neighbor micro-grids. *IET Generation, Transmission & Distribution*, No. 13, pp. 380-389, 2019.
- [8] A. Mehrtash, P. Wang, L. Goel, "Reliability evaluation of restructured power systems using a novel optimal power-flow-based approach," *IET Gener. Transm. Distrib*, No. 2(7), pp. 192-199, Feb. 2013.
- [9] K. Tanaka, K. Ogimi, A. Yona, T. Funabashi, "Optimal Operation by Controllable Loads Based on Smart Grid Topology Considering Insolation Forecasted Error," *IEEE Trans. Smart Grid*, No. 3(9), pp. 438-444, 2012.
- [10] G. V. K. Murthy, S. Sivanagaraju, S. Satyana rayana, B. Hanumantha Rao, "Voltage stability index of radial distribution networks with distributed generation," *Int. J. Electr. Eng.*, No. 6(5), pp. 791-803, 2012.
- [11] H. Farzi, M. Moeini-Aghaie, M. Fotuhi-Firuzabad, "Role of Outage Management Strategy in Reliability Performance of Multi-Microgrid Distribution Systems", *IEEE Trans. Power Syst.*, vol. 33, no. 3, pp. 2359-2369, 2018.
- [12] M. Silva, H. Morais, Z. Vale, An integrated approach for distributed energy resource short-term scheduling in smart grids considering realistic power system simulation. *Energy Convers Manage*, No. 64, pp. 273-88, 2012.
- [13] F.S. Gazijahani, J. Salehi, "Robust design of microgrids with reconfigurable topology under severe uncertainty", *IEEE Trans. Sustain. Energy*, No. 2(9), pp. 559-569, 2018.
- [14] S. Bera, S. Misra, JJPC. Rodrigues, Cloud computing applications for smart grid: a survey. *IEEE Trans Parallel Distrib Syst*, No. 26, pp. 1477-94, 2015.
- [15] Y. Levron, J. M. Guerrero, Y. Beck, "Optimal power flow in microgrids with energy storage," *IEEE Trans. Power Syst.*, No. 3(28), pp. 3226-3234, 2013.
- [16] A. Shabanpour- Haghghi, AR. Seifi, Multi-objective operation management of a Multi - carrier energy system. *Energy*, No. 88, PP. 430-42, 2015.
- [17] S. Derafshi Beigvand, H. Abdi, M. La Scala, Optimal operation of multicarrier energy systems using time varying acceleration coefficient gravitational search algorithm. *Energy*, No. 114, pp.253-65, 2016.
- [18] A. Sheikhi, M. Rayati, S. Bahrami, AM. Ranjbar, S. Sattari, A cloud computing Frame work on demand side management game in smart energy hubs. *Int J Electr Power Energy Syst*, No.64, pp.1007-1016, 2015.
- [19] A. Sheikhi, S. Bahrami, AM. Ranjbar, An autonomous demand response program for electricity and natural gas networks in smart energy hubs. *Energy*, No. 89, pp. 490-499, 2015.
- [20] A. Sheikhi, M. Rayati, S. Bahrami, AM. Ranjbar, Integrated demand side management game in smart energy hubs. *IEEE Trans Smart Grid*, No. 6, pp. 675-683, 2015.
- [21] S. Bahrami, A. Sheikhi, From demand response in smart grid toward integrated demand response in smart energy hub. *IEEE Trans Smart Grid*, No.7, 650-658, 2016.
- [22] M. Rayatia, A. Sheikhia, AM. Ranjbara, Optimising operational cost of a smart energy hub, the reinforcement learning approach. *Int J Parallel, Emergent*

- Distrib Syst, No. 30, pp.325–41, 2015.
- [23] KW. Hedman, SS. Oren, RP. O’Neill, A review of transmission switching and network topology optimization, Proc. IEEE Power and Energy Soc. General Meeting, 2017.
- [24] A. Mazi, BF. Wollenberg, MH. Hesse, “Corrective control of power system flows by line and bus-bar switching,” IEEE Trans. Power Syst., No. 1(3), pp. 258-266, 2016.
- [25] A. Luna, L. Meng, N. Diaz, “Online energy management systems for microgrids: experimental validation and assessment framework”. IEEE Trans Power Electron, No. 33, pp. 2201-2212, 2018.