



Voltage Sag Investigation of Microgrid in the presence of SMES and SVC

Noorollah Fardad¹, Soodabeh Soleymani^{1*}, Faramarz Faghihi¹

¹Department of Electrical Engineering, Science and Research Branch, Islamic Azad University, Tehran, Iran.

Received: 22-Nov-2018, Revised: 2-Jan-2019, Accepted: 5-Jan-2019

Abstract

A Doubly Fed Induction Generator (DFIG)-based wind power generation system in microgrid significantly affects the power system operation. This paper describes the behavior of a microgrid with DFIG's by use of control strategies under voltage sag conditions. Superconducting Magnetic Energy Storage (SMES) unit and a Static Var Compensator (SVC) are employed to increase the operation of a wind power generation system based on DFIG during a voltage sag. Comprehensive simulation with the relevant details is performed using MatLab/Simulink software to define the effect of the SMES and SVC units by increasing the efficiency and performance of the system during voltage sag condition in a microgrid and the results are compared. For optimal use of the SMES and SVC units, economic considerations are applied.

Keywords: SMES, SVC, Voltage sag, Microgrid, DFIG.

1. INTRODUCTION

Voltage sag is one of the problems related to power quality. This event occurs continuously in transmission and distribution systems. Voltage sag which results due to a fault or a pulsed load can cause an interruption on critical and urgent load. Even relay and conductors in motor starters can be sensitive to voltage sag resulting in the shutdown of a process. Inappropriate operation of the electrical

equipment has caused reduction of efficiency increase losses. Voltage sag is very high-risk during the control of equipment in the process industry and any failure of control make a breakdown of the process [1].

Currently, due to the increasing application of power electronics devices, microgrids are able to operate in both grid-connected and island modes. As such, energy management and the categorization of a system control strategy are required for microgrid operation. The microgrid system is assumed to be a part of a system and is

*Corresponding Author's Email:
s.soleymani@srbiau.ac.ir

supplied by six variable-speed wind turbine with DFIG [2]-[5].

According to the power system requirements, the real power can be absorbed or released from the low loss superconducting magnetic coil. The firing angle of the converters of the SMES unit controls the quantity of energy to be supplied or received by the SMES unit.

With fuzzy logic, schemes can be represented with degrees of truthfulness. Fuzzy logic is an effective tool with a several application in embedded control and information processing. Fuzzy inference is the process of formulating the mapping from a given input to an output using fuzzy logic. A control system for the SMES unit based on hysteresis current control jointly with fuzzy logic control is used [6].

Static VAR Compensator (SVC) can control the required bus voltage by improving the voltage profile of the system. The primary function of an SVC is to keep the voltage at a certain bus through reactive power compensation. SVCs have been used to enhance the performance of the system at steady state and transient voltage control. SVCs are also used to decrease power fluctuations, improve transient stability and reduce system losses by optimized reactive power control. SVC is used for load balancing and maintaining of power quality in an island microgrid. SVC is set near the load to reactive power compensation to mitigate the voltage variation. During a large amount of reactive injection into the network, using SVC is desirable application with efficient cost [7]-[10].

The main drawbacks of SMES units are the high cost and environmental issues associated with the strong magnetic field. The capability of SMES for transient stability enhancement has been demonstrated for a balanced fault in power systems [11]-[12].

In this paper, the response of DFIG-based wind power generation systems during voltage sag when applying SVC and SMES is examined and the achieved results are compared. A sudden drop in the point of common coupling (PCC) voltage causes a large current to flow in the rotor, so comparing the reply of each device, in this case, is reviewed. The affected system active power and capacitor dc link voltage are also studied. The system is simulated and calculated with MatLab/Simulink software. Based on the simulation results and economic evaluation, the use of SMES and SVC in a microgrid is analyzed.

2. MICROGRID SYSTEM CONFIGURATION

Fig.1 illustrates a microgrid that it has isolated from the power grid. The network has six 1.5-MW DFIGs. The DFIG contains of an induction generator. The microgrid is connected to the wind turbines via a 30-km transmission line and Δ/Y step-up transformer. For the average wind speed of 15 m/s, which is used in this investigation, the turbine output power is 1.0 p.u, and the generator speed is 1.2 p.u. A SMES and an SVC connected to the PCC in order to improve the dynamic performance of DFIG during voltage sag study. The capacity of SMES and SVC units is strongly related to the capacity of the wind power generation system.

The SMES/SVC units are connected to the 25 kV bus via T7 transformer. Two loads are located in BUS2 and PCC. The parameters for the wind turbine model are given in Table 1.

3. MODELING OF DFIG SYSTEM WITH SVC

SVC is a shunt-connected reactive power compensation device that is capable of generating or absorbing reactive power. The

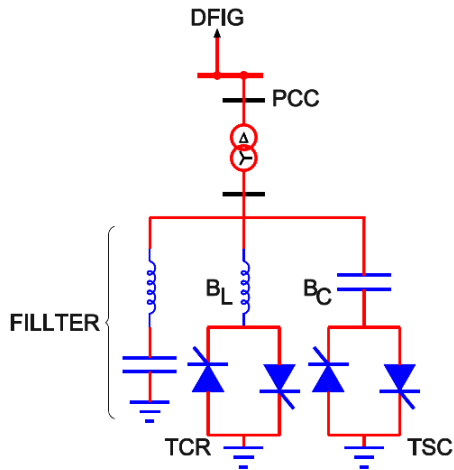

Fig. 2. SVC coupled with DFIG.

The SVC can be operated in two different modes; voltage regulation mode and Var control mode (the SVC susceptance is kept constant.). If the SVC susceptance (B) stays within the maximum and minimum susceptance values imposed by the total reactive power of capacitor banks (B_{Cmax}) and reactor banks (B_{Lmax}), then the voltage is regulated at the reference voltage V_{ref} . By controlling the firing angle of thyristors through a PI (Proportional + Integral) controller, the effective reactance of the SVC is varied [14].

4. MODELING OF DFIG SYSTEM WITH SMES

When energy is charged or discharged during operation, the current and magnetic field of the superconducting magnet change. Then the eddy current and magnetization loss occur in the SMES system.

The SMES unit in this study contains two winding transformer with Dy vector group and 25/6kv voltage level, a thyristor controlled bridge ac to dc converter, and a 0.5 H superconducting coil. The converter implies the supplied voltage across the superconducting coil. The charge and discharge controls can easily be acquired by altering the delay angle (α) controlling the thyristor's sequent firing. As it is shown in

Fig. 3(a), in case of α below 90° , the converter acts in the rectifier status (charging) and according to Fig. 3(b) when α is above 90° , the converter acts in the inverter status (discharging). So, based on the system prerequisites, the direction of power injection to the power system can be specified (absorption from or injection to the system) [15].

Depending upon the values of chopper duty cycle (D), three zones of operation can be categorized for the chopper arrangement. The timing diagrams belong to these areas of operation are shown in Fig. 3(c), in which for charge/discharge/standby operation, the value of $S=+1/-1/0$. It is clearly shown in Fig. 3(c) that average voltage appearing across the SMES coil and chopper current at any instant of time can be expressed by Eqs. (1) and (2),

$$V_{SM-av} = [1 - 2D]V_{dc-av} \quad (1)$$

$$I_{dc-av} = [1 - 2D]I_{SM-av} \quad (2)$$

where V_{SM-av} is the average SMES coil voltage, I_{SM-av} is the average current through the SMES coil, V_{dc-av} is the average dc source voltage, I_{dc-av} is the average dc source current, and D is the duty cycle of the chopper.

Based on the positive and negative values of the average voltage across the SMES coil, it is charged or discharged. It could be done with the dc-dc chopper duty cycle (D) controlled by the fuzzy logic controller (FLC). During the amount of duty cycle is greater than 0.5, coil is in charging mode and in the case of the duty cycle being less than 0.5, the coil is in discharging mode [16].

A dc link capacitor of 50 mF is placed between VSC and the DC-DC chopper. For a SMES system, the inductively stored energy (E in Joule) and the rated power (P in Watt) can be expressed as,

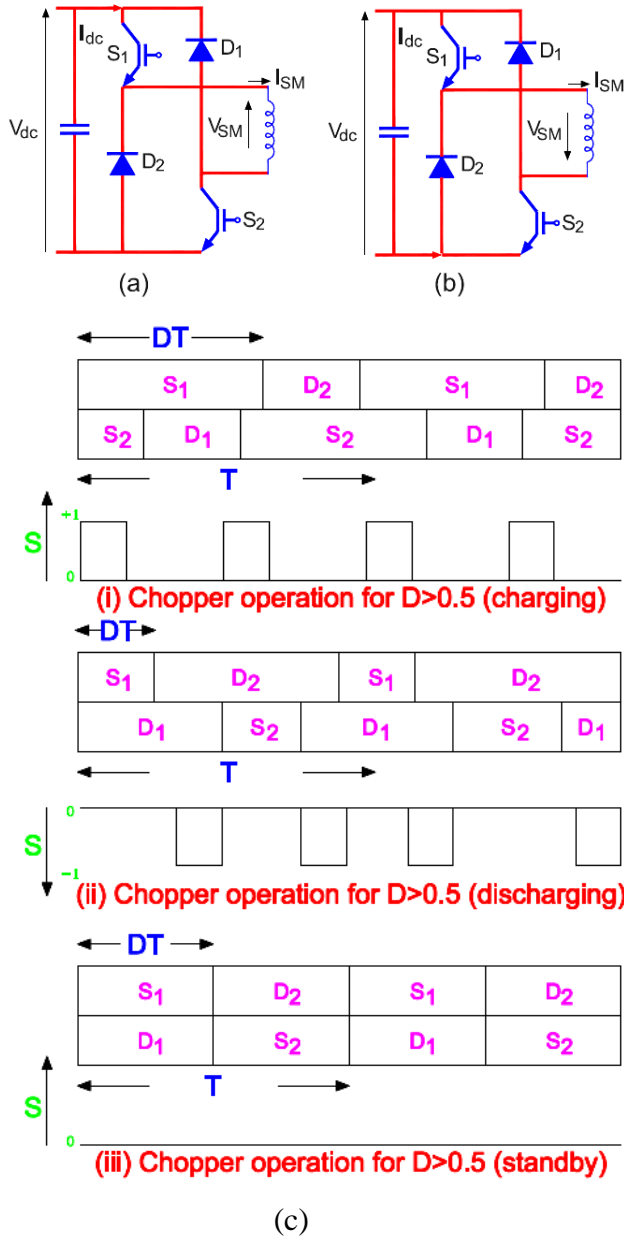

Fig. 3. (a) Charging mode, (b) Discharging mode, (c) Details of switching positions for equivalent chopper operation.

$$E = \frac{1}{2} I_{SM}^2 L_{SM} \quad (3)$$

$$P = \frac{dE}{dt} = L_{SM} I_{SM} \frac{dI_{SM}}{dt} = V_{SM} I_{SM} \quad (4)$$

where L_{SM} is the inductance of the coil, I_{SM} is the dc current flowing through the coil and V_{SM} is the voltage across the coil.

5. CONTROL STRATEGIES

The SMES configuration used in this

paper consists of a VSC and dc–dc chopper, as shown in Fig. 4. The converter and the chopper are controlled using a hysteresis current controller (HCC) and a fuzzy logic controller (FLC), respectively.

A. Hysteresis Current Controller

The current control of converter is a hysteresis current controller. It is employed due to simple, fast dynamic response and unaffected to load parameters. In this method, each phase consists of a comparator and a hysteresis band. The switching signals are produced due to the error in the current. By comparing the reference current and actual current, the error generates. The main function of this approach of control is to force the input current to follow the reference current in each phase. In this method of control, the deviation of the current between the upper and lower in the hysteresis band is limited [17].

To keep the advantages of the hysteresis methods, this phase dependence can be minimized by using the phase-locked loop (PLL) method to keep the converter switching at a fixed prearranged frequency level. The SMES with an auxiliary PLL controller is shown in Fig. 5. The HCC is comparing the three-phase line currents (I_{abc}) with the reference currents (I_{abc}^*), which is placed by the I_d^* and I_q^* references.

B. FLC

The fuzzy logic controller is one of the most practically effective approaches to design a controller for applying the qualitative capability of a system and to solve a problem with ambiguity or uncertainty. The fuzzy logic controller involves with fuzzification, rule base and defuzzification [15].

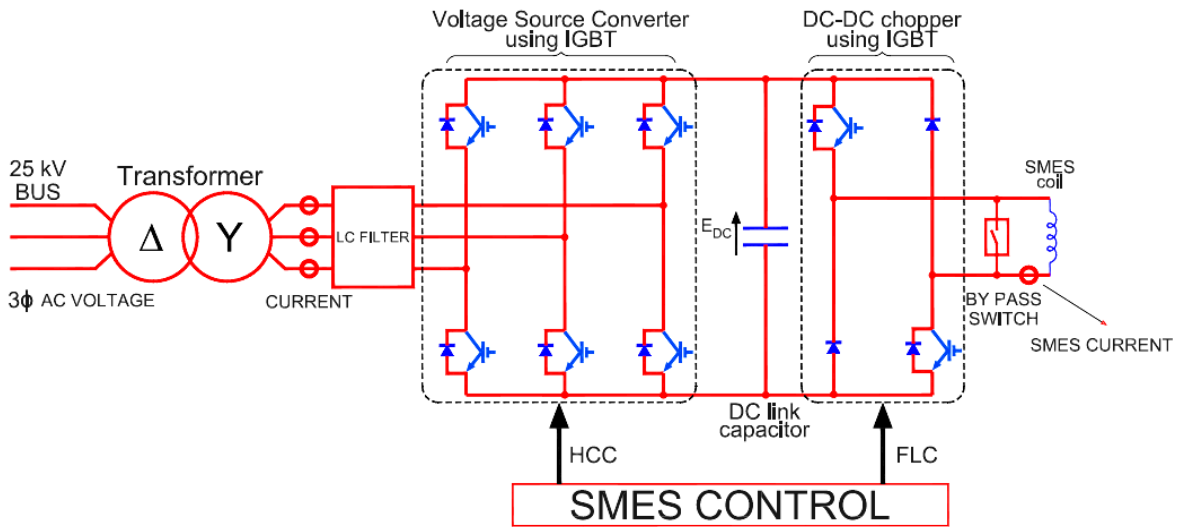

Fig. 4. SMES control configuration.

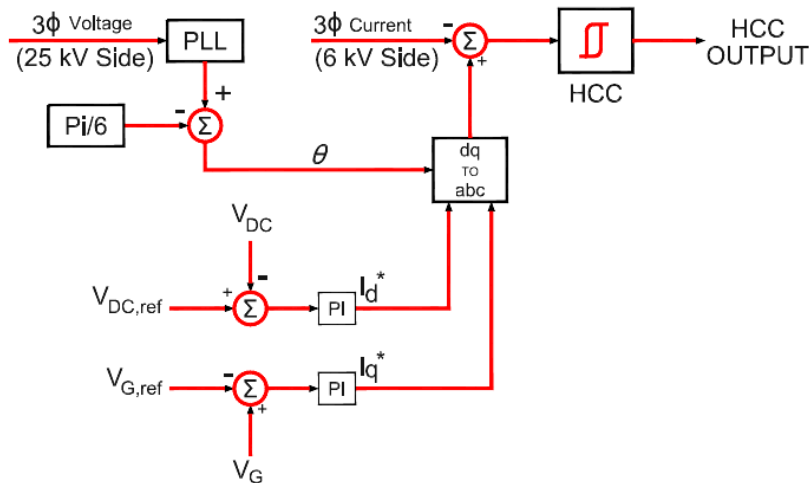

Fig. 5. Hysteresis current controller scheme.

To control power transfer between the SMES coil and the ac system, a dc-dc chopper is applied, and fuzzy logic is selected to control its duty cycle (D). In order to generate the gate signals for the IGBT's of the chopper, the reference signal of PWM is compared with the sawtooth carrier signal as shown in Fig. 6. The frequency of the sawtooth carrier signal for the chopper is chosen 100 Hz.

Input variables for the model are the real power generated by the DFIG and the SMES coil current. The duty cycle defines the direction and the magnitude of the power exchange between the SMES coil and the ac system. If the duty cycle (D) is equal to 0.5,

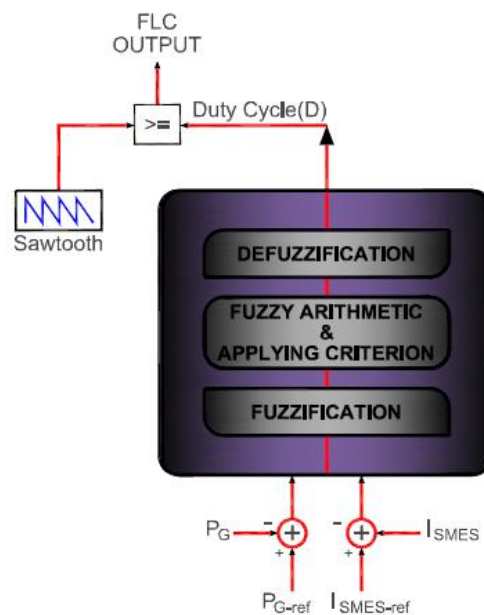

Fig. 6. FLC control structure.

the coil does not take any action, and the system is under normal operating status. Under this condition, a bypass switch that is placed across the SMES coil (shown in Fig. 4) will be closed to avoid the draining process of SMES energy during normal operating conditions.

The control strategy is simple, having a single-input-single-output (SISO) variable makes the fuzzy controller straightforward [18]-[20]. The control rules of the controller are determined from the view of practical system operation and by trial and error.

Making a logical conclusion is the basic operation of the inference engine. In fact, the inference engine is a program which employs the rule base and the input data to the controller to reach the conclusion. The outcome of the inference engine is the fuzzy output of the controller, which finally becomes the input to the defuzzification interface. For the inference mechanism of the FLC, Mamdani's method has been utilized [15].

6. COST MODELING

A large portion price of SMES systems is related to superconducting materials. A complete economic investigation involves estimating the life cycle cost, which contains capital cost, operating cost and maintenance cost. Two crucial items for the capital cost, need to be considered: the cost related to energy capacity and the cost related to power conversion. The first item consists of capital and construction costs of superconductors, magnet structure components, cryogenic vessels, and cooling, protection, and control circuits. The latter is the cost of a required power electronics circuit. For different practical condition, different power electronics circuits are required. As a result, the cost varies in different cases [21].

For a transmission application, SMES system costs are achieved by the operational requirements. The cost of the SMES coil is mainly determined by the amount of energy that must be stored. The main reason for the wide difference in the cost of the power conversion system is its requirement on the configuration of the system. Especially, if the SMES is connected by a voltage source or current source inverter, or if the SMES is related to an existing system that it requires only a DC-DC chopper [22].

The costs for SVCs vary based on capacity and the assumptions made regarding the simplicity of installation. The investment cost in FACTS devices is cost-effective and important. According to the Siemens AG Database [23], the cost function of the UPFC, TCSC and SVC equipment are as follows:

$$C_{UPFC} = 0.0003Q^2 - 0.269Q + 188.22 \quad (5)$$

$$C_{TCSC} = 0.0015Q^2 - 0.713Q + 153.75 \quad (6)$$

$$C_{SVC} = 0.0003Q^2 - 0.305Q + 127.38 \quad (7)$$

where, Q is the reactive power capacity of FACTS devices, in MVar. C_{UPFC} , C_{TCSC} and C_{SVC} are in US\$ / KVAR.

With careful consideration of these cost functions, it can be seen that at low powers, SVC has been lower costs (see Fig. 7). Therefore, comparable with SMES and for improving the system performance, SVC analysis was studied. Based on the examination and also evaluation of the costs of SVC and SMES, it is deduced that the use of SVC is more cost-effective.

7. SIMULATION RESULTS

The performance of the system, with SMES or with SVC during voltage sag occurrence from $t=4$ sec till $t=4.1$ sec are investigated and the achieved results are compared.

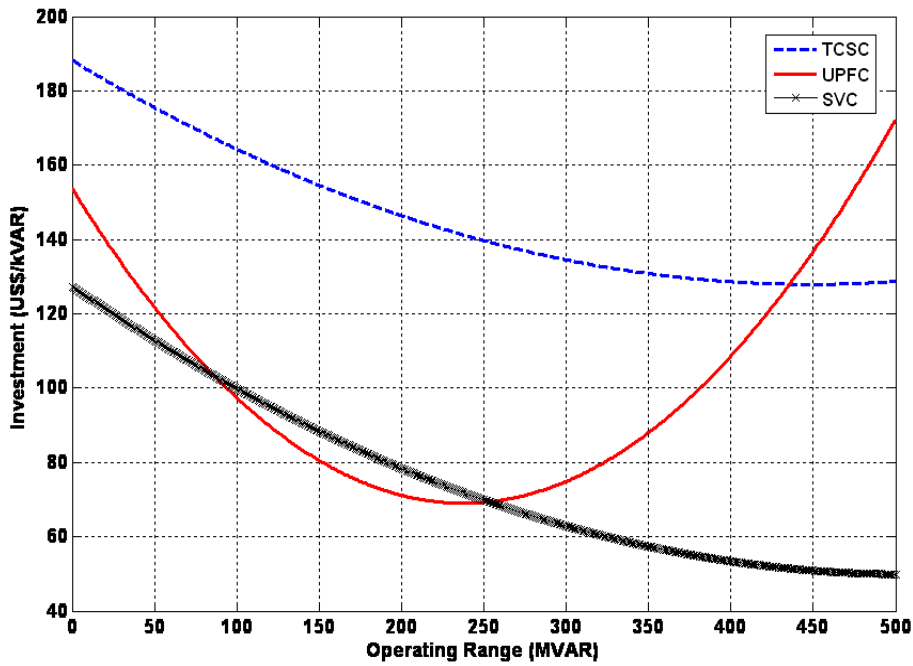
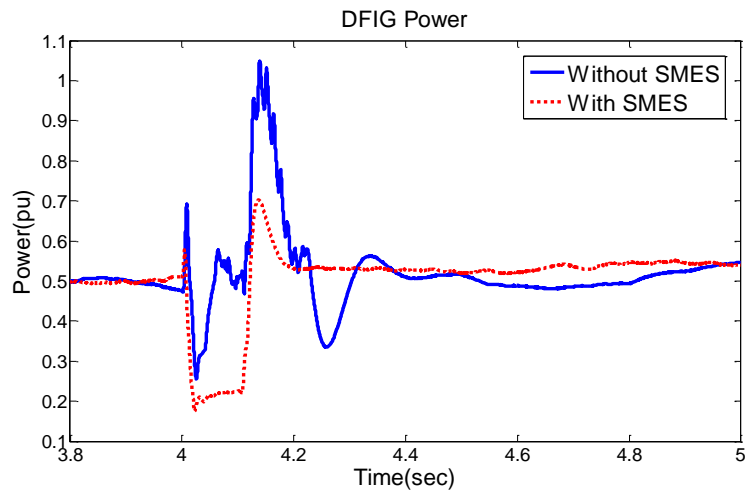
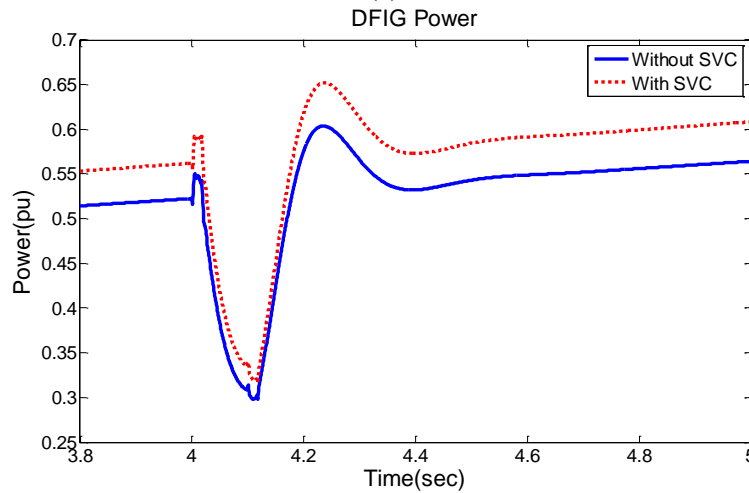

Fig. 7. Comparable cost of TCSC, UPFC and SVC.



(a)



(b)

Fig. 8. DFIG Power, (a) Using SMES (b) Using SVC.

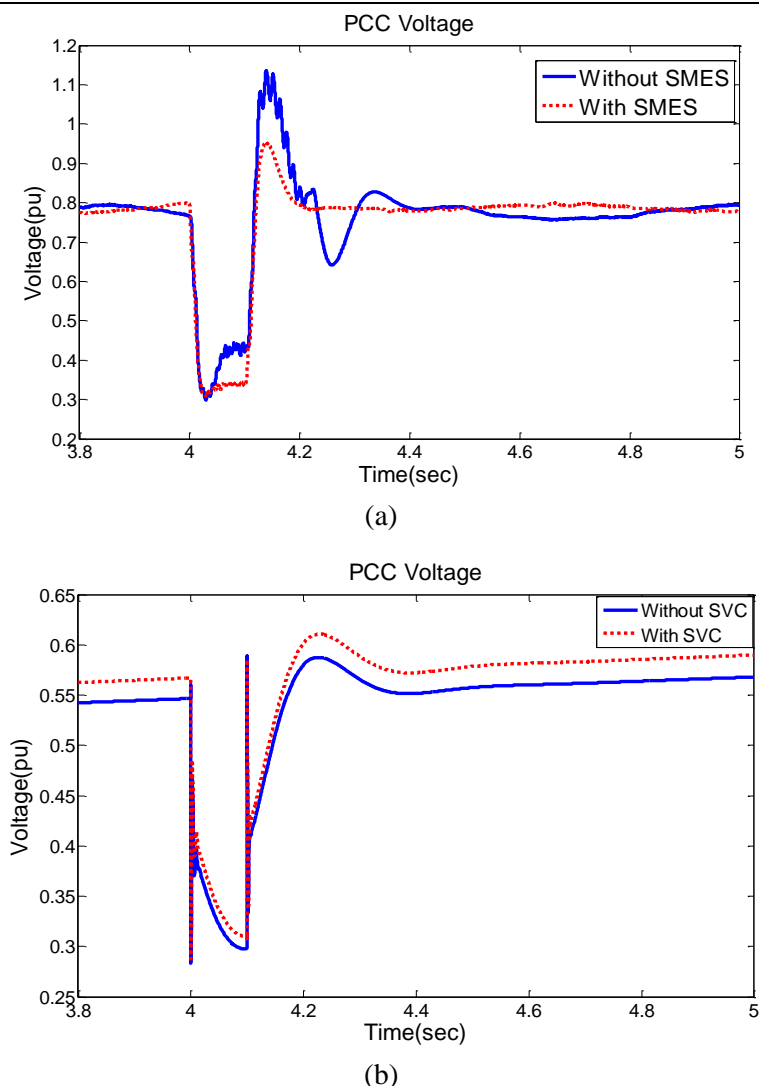

Fig. 9. PCC Voltage, (a) Using SMES (b) Using SVC.

These simulations are carried out in MatLab/Simulink depends mainly on the type and the resistance of the fault, the distance to the fault and the system configuration. In the studied system, SMES and SVC need some time to reach the steady-state value after the fault is cleared. Therefore, for better clarification, the simulation results are shown for 3.8 sec to 5 sec.

Fig. 8 shows the DFIG active power for the system employing SMES or SVC. SMES and SVC can adjust the active and reactive power input to the system, restrain the power oscillation of the system and the system can be returned to the steady-state. Practically, SMES and SVC have the capability to suppress power oscillation and

to improve the system performance. Since SMES and SVC are capable of controlling both active and reactive powers simultaneously, they can act as proper devices in order to stabilize the microgrid with the high level of operation of DFIG's. The results indicate that the improved performance with SMES slightly in comparison with SVC.

Fig. 9 illustrates the PCC voltage for the system using SMES and SVC at PCC. It can be found that the voltage drops during voltage sag. At that time, SVC and SMES start to deliver the reactive power to compensate for the voltage drop. The voltage fluctuations are less significant and stabilized to a steady state very fast.

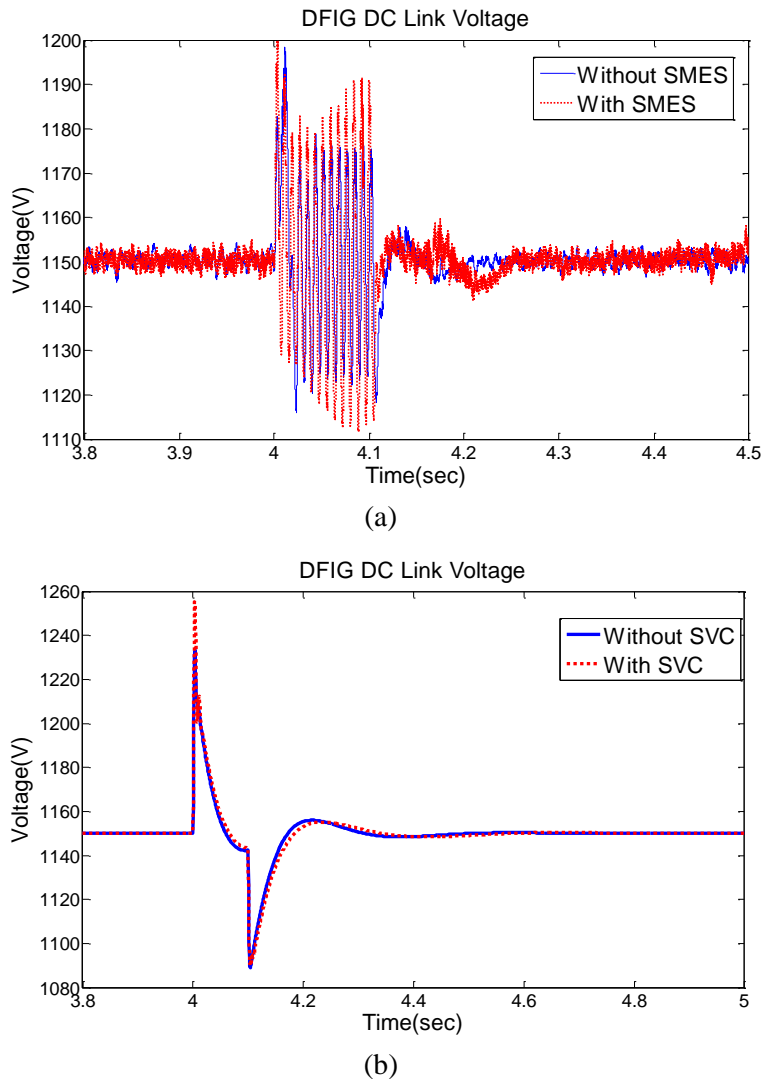

Fig. 10. DFIG DC Link Voltage, (a) applying SMES (b) applying SVC.

Fig. 10 illustrates DC-Link voltage. The instantaneous oscillation of the active power produces the oscillation in the DC-link voltage. The voltage overshoot across the dc-link capacitor during fault clearance is slightly reduced with the SMES and SVC unit connected to the system.

It is clearly observed from the comparative simulation results that the transient responses of the DFIG exhibit good damping performance when the SVC and SMES are included in the system.

8. CONCLUSION

It is observed that during islanding and due to self-excitation phenomenon, the induction

generator may be subjected to high over-voltages. A static Var compensator (SVC) and also a SMES are introduced in the wind turbine doubly fed induction generation to mitigate the voltage sag. The respective waveforms are verified without and with SMES and SVC under voltage sag. The results indicate that the effect of SVC and SMES to compensate the voltage sag approximately is equal, in this regard, the required power is important in system analysis and on this basis; it can be stated about the application of the SVC and SMES both technically and economically. Based on a per unit active and reactive power, SMES costs will be added to the SVC costs.

REFERENCES

- [1] M. Manikandan, A. Mahabub Basha, "Power quality compensation using SMES," *International Journal of Advances in Engineering & Technology*, vol. 6, no.4, pp. 1855-1868, 2013.
- [2] P. Basak, "A literature review on integration of distributed energy resources in the perspective of control, protection and stability of microgrid," *Renewable and Sustainable Energy Reviews*, vol. 16, pp. 5545-5556, 2012.
- [3] M. Shahabi, M. R. Haghifam, M. Mohamadian, S. A. Nabavi-Niaki, "Microgrid Dynamic Performance Improvement Using a Doubly Fed Induction Wind Generator," *IEEE Transactions on Energy Conversion*, vol. 24, no. 1, pp.137-145, 2009.
- [4] J.E. Calderon, H.R. Chamorro ,G. Ramos, "Advanced SVC intelligent intron to improve power quality in microgrids," *Alternative Energies and Energy Quality (SIFAE)*, 2012 *IEEE International Symposium on*, PP.1-6, Oct. 2012
- [5] O. Palizban, K. Kauhaniemi, "Microgrid Control Principles in Island Mode Operation," *Power Tech 2013 IEEE Grenoble*, pp.1-6, June 2013.
- [6] A. M. Shiddiq Yunus, A. S. Masoum A. Abu-Siada," Application of SMES to enhance the dynamic performance of DFIG during voltage sag and swell," *IEEE Transactions on applied superconductivity*, vol. 22, no. 4, 2012.
- [7] M. Zhengbo, L. Linchuan and D. Tuo, "Application of a combined system to enhance power quality in an island microgrid," *Power Engineering and Automation Conference (PEAM) IEEE*, vol.3, pp.326-330, 2011.
- [8] L. Wang and Q. Son Vo, "Power Flow Control and Stability Improvement of Connecting an Offshore Wind Farm to a One-Machine Infinite-Bus System Using a Static Synchronous Series Compensator", *IEEE Transactions on Sustainable Energy*, vol.4 , 2013.
- [9] A. Sharma, R. Kaur, "Voltage Sag mitigation using shunt FACT devices in Induction Motor Drives," *International Journal of Innovative Science, Engineering & Technology*, vol. 1, 2014.
- [10] T. Masaud, P.K. Sen, "A comparative study of the implementation of STATCOM and SVC on DFIG-based wind farm connected to a power system," *IEEE Power and Energy Society General Meeting*, pp.1, 2012.
- [11] A. Demiroren, H. L. Zeynelgil, "The transient stability enhancement of synchronous machine with SMES by using adaptive control," *Electric Power Components Syst.*, vol. 30, pp. 233–249, 2002.
- [12] M. ANJU, R. RAJASEKARAN, "Co-ordination of SMES with STATCOM for mitigating SSR and damping power system oscillations in a series compensated wind power system, ", 2013 *International Conference on Computer Communication and Informatics (ICCCI -2013)*, Jan., 2013
- [13] N. G. Hingorani, L. Gyugyi, "Understanding FACTS; Concepts and technology of flexible ac transmission Systems," *IEEE Press book*, 2000.
- [14] N. Hasan, Ibrahim, S. Farooq, "Dynamic performance analysis of DFIG based wind farm with STATCOM and SVC," *International Journal of Emerging Technology and Advanced Engineering*, vol. 2, 2012.

- [15] D. Harikrishna, N.V. Srikanth, Y. Chandrasekhar, "Improvement of transient stability using fuzzy logic controlled SMES in Matlab," *Majlesi Journal of Electrical Engineering*, vol. 5, no. 4, 2011.
- [16] M.R.I. Sheikh, J. Tamura, "Smoothing control of wind farm output fluctuations by fuzzy logic controlled SMES," *International Journal of Electrical and Computer Engineering (IJECE)*, vol.1, no.2, 2011.
- [17] H. M. Soliman, S.M.EL. Hakim, "Improved hysteresis current controller to drive permanent magnet synchronous motors through the field oriented control," *International Journal of Soft Computing and Engineering (IJSCE)*, vol.2, 2012.
- [18] M. H. Ali, T. Murata, and J. Tamura, "The effect of temperature rise of the fuzzy logic-controlled braking resistors on transient stability," *IEEE Transactions on Power Sys.*, vol. 19, no. 2, pp. 1085–1095, 2004.
- [19] M. H. Ali, Y. Soma, T. Murata, and J. Tamura, "Transient stability improvement by fuzzy logic controlled braking resistor," *International Journal of Power Energy System*, vol. 25, no. 3, pp. 143–150, 2005.
- [20] M. H. Ali, Y. Soma, T. Murata, and J. Tamura, "A fuzzy logic controlled superconducting magnetic energy storage for transient stability augmentation," *IEEE Transactions on Control Sys.*, vol. 15, no. 1, pp. 144–150, 2007.
- [21] J. Zhu, H. Zhang, W. Yuan, M. Zhang, X. Lai, "Design and cost estimation of superconducting magnetic energy storage (SMES) systems for power grids," *IEEE Power and Energy Society General Meeting (PES)*, PP. 1-5, 2013.
- [22] V. Karasik, K. Dixon, C. Weber, B. Batchelder, G. Campbell, and P. Ribeiro, "SMES For Power Utility Applications: A Review of Technical and Cost Considerations", *IEEE Transactions on applied superconductivity*, vol. 9, no. 2, 1999.
- [23] L.J.Cai and Erlich, "Optimal choice and allocation of FACTS devices in deregulated electricity market using genetic algorithms", *Power Systems Conference and Exposition*, 2004. vol.1, pp. 201 – 207, 2004.