

A Novel PM Shape For Reducing Cogging Torque In AFPMSM

Hamed Farnaghizad¹, Hamid Lesani^{2*}

¹ Electrical Engineering Department, South Tehran Branch, Islamic Azad University,
Tehran, Iran

² Electrical Engineering and Computer Science Department, Tehran University

Received: 14-Aug-2018, Accepted: 28-Oct-2018

Abstract

Torque ripple in electrical machines is an important issue which may cause several problems in use. In permanent magnet machines and machines with DC excitation, main part of torque ripple is because of cogging torque. There are several ways to reduce this torque and in permanent magnet machines, optimized shape of permanent magnets is one of them. In this paper, a novel shape of permanent magnet in an Axial Flux Permanent Magnet Synchronous Machine (AFPMSM) is proposed which reduces the motor cogging torque and hence over come the torque ripple. First, reference motor is designed with conventional PM shape and then novel PM shaped AFPMSM is designed. These two machines are analyzed by MAXWELL software and then their torque ripples are computed. Results show 35 percent reduction of cogging torque.

Keywords: Permanent Magnet, Shape, Torque Ripple, AFPMSM, Cogging Torque.

1. INTRODUCTION

The need for energy sources to meet energy requirements emerged from growing-population and developing technology is going up day by day. Nowadays, due to the reduction of fossil fuels in electricity generation and increase in environmental awareness, popularity

of renewable energy sources (RESs) has increased [1]. Using hybrid vehicles is one of best ways to reduce fossil fuel consumption. The main part of hybrid vehicles is electric motor where the axial flux permanent magnet synchronous motors (AFPMSM) are popular for this kind of vehicles. Compared to the Radial Flux Synchronous Machines, the

*Corresponding Author's Email: lesani@ut.ac.ir

AFPMSMs offer advantages in some applications. In general, AFPMSMs have a compact and robust structure, the length of the air-gap is small, their volume is limited and their efficiency and power-to-weight ratio are high [2].

PM machines are increasingly becoming dominant machines with the cost competitiveness of high energy permanent magnets. These machines offer many unique features. They are usually more efficient because of the fact that field excitation losses are eliminated resulting in significant rotor loss reduction [3]. One of the most important problems in PM machines is torque ripple which are in both radial flux and axial flux machines.

The main sources of torque ripple are: a) cogging torque, b) pulse width modulation (PWM) current harmonics, c) non ideal back electromotive force (EMF) waveforms, d) phase commutation events, and e) causes such as dc-link voltage pulsation and inverter dead-time. At high speeds, torque ripple is usually filtered out by the system inertia. However, at low speeds, torque ripple may result in an unacceptable speed variation, vibration and acoustic noise [4].

Cogging torque occurs from the variation of magnetic permanence of the stator teeth and the slots above the permanent magnets as the rotor rotates. The presence of cogging torque is a major concern in designing the permanent magnet machines since it adds unwanted harmonics to the pulsating torque. Ripple torque is mainly due to the fluctuations of the field distribution and the armature MMF which depends on the motor magnetic structure and the armature current waveform [5]. Similar to the conventional radial flux permanent magnet (RFPM) machines, AFPM machines also produce undesirable torque ripples in the developed electromagnetic torque that affect their output performance [6].

Property of the materials used in the machine is so important for this issue. The new age of permanent magnet machines is characterized by high flux density in the air gap. These machines are attractive due to their high power density [7].

The various rotor modification techniques are directly applicable to axial flux machines. However, the stator modification techniques cannot be directly applied due to difficulty in punching slots in axial stator laminations leading to high cost [8]. In this paper, cogging torque reduction of an axial flux surface mounted permanent magnet synchronous motor with TORUS topology is discussed by new shape of permanent magnets. Results show that this new shape leads to over 35 percent cogging torque reduction in respect with commercial shape. These motors are suitable for traction use in hybrid and electric vehicles as their compatibility in weight and power density.

2. COGGING TORQUE REDUCTION TECHNIQUES IN PM MACHINES

The cogging torque is caused by the variation of the magnetic energy stored in the air gap, due to the permanent magnet flux with the angular position of the rotor. In more detail, it appears that due to the interaction between the rotor magnetic flux (φ_{ag}) and the variation of the stator's reluctance (R), by the slotting [7], see Eq. (1).

$$T_{cogg} = \sum_1^P \left(-\frac{1}{2} \varphi_{ag}^2 \frac{dR}{d\theta} \right) \quad (1)$$

Also, the cogging torque can be described by Fourier series as,

$$T_{cogg}(\theta_m) = \sum_{k=1}^{\infty} T_k \sin(kN_c \theta_m + \varphi_k) \quad (2)$$

The cogging torque can be computed by finite-element analysis using either Maxwell's

stress tensor or the virtual work technique [4]. In general, the total torque of a PM machine has three torque components: average torque, ripple torque and cogging torque [4]. Many methods put effort to reduce the cogging torque of PM machines, including shape of magnets, using dummy slots and motor's driver control strategy. Although, adding dummy slots reduce amplitude of the cogging torque and increase its frequency, the manufacturing process will get complicated.

In the design of surface-mounted permanent-magnet motors, the shape of the magnets plays a crucial role, since this influences both the electromotive force (EMF) and the cogging torque. The possible ways of acting on the geometry of the magnets have been studied extensively in the literature: modifying the shape of the edges [9]. The cogging torque depends on two parameters. The first was flux imposed in the air gap by the magnet [7].

In [4], [7] and [9] impact of different shapes of permanent magnets are tested on reducing the cogging torque. As approved in [4], one of the best ways to reduce cogging torque is skewing permanent magnets as it is shown in Fig. 1.

The smallest skew angle for minimizing the cogging torque [4] is,

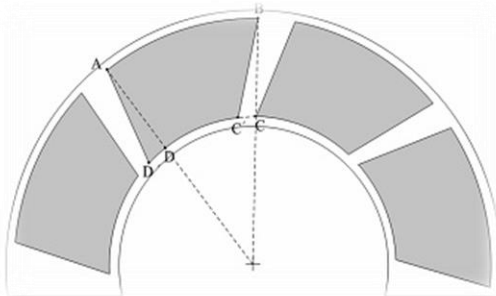

Fig. 1. Skewed PMs of AFPM motor [2].

$$\theta_{skew} = \frac{2\pi}{N_c} \quad (3)$$

where N_c is the least common multiple between the number of rotor poles, $2p$, and the number of stator slots, N_s , when the number of slots per pole is an integer, $N_c = N_s$.

In [6], it was suggested that using both skewed permanent magnets and the stator side displacement are the best techniques to reduce the cogging torque.

In [7], the cogging torque cancelation is done by reshaping permanent magnets as shown in Fig. 2.

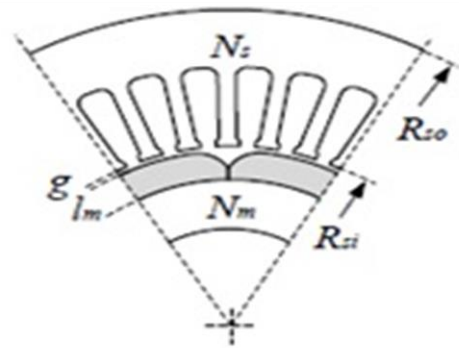

Fig. 2. Configuration of the motor in Ref. [6].

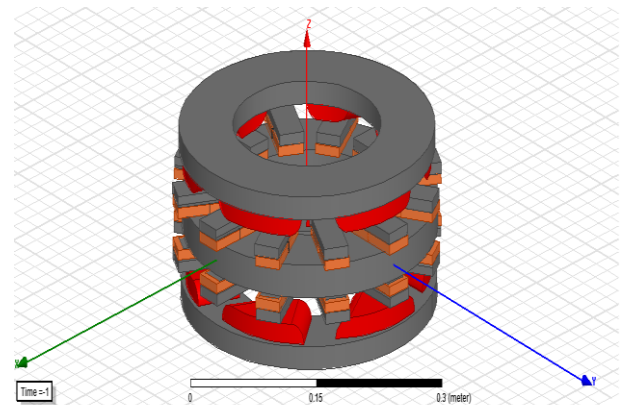

Fig. 3. Reference Motor with TORUS Topology.

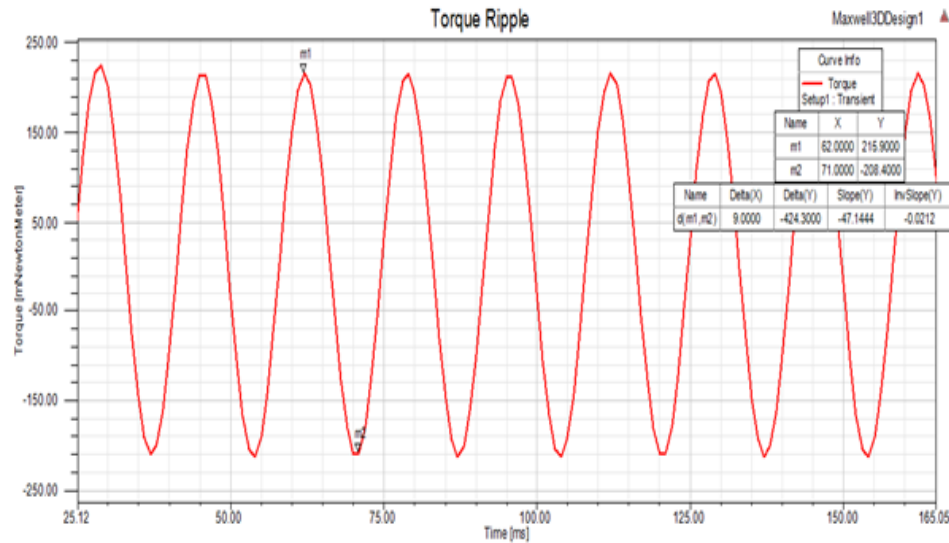

Fig. 4. Torque ripple of reference motor is shown.

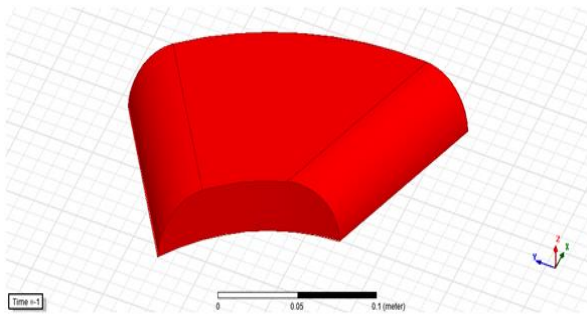

Fig. 5. Improved PM shape.

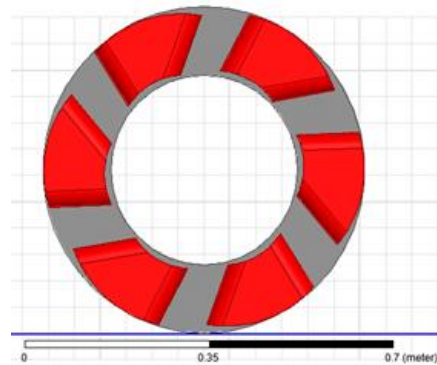

Fig. 6. Rotor with improved PM shapes.

3. REFERENCE MACHINE PARAMETERS

Reference axial flux permanent magnet motor is TORUS type with two rotors and one stator, Fig. 3, and parameters of the machine is shown in Table 1. Reference motor is based on [10] which has three phases with six poles motor and is suitable for hybrid vehicles, due to high power density of these kinds of machines.

PMs of the axial flux machine are skewed just like what is shown in Fig. 1. As mentioned before skewed permanent magnets are recommended to reduce the cogging torque. PMs are made of FeNd35.

For computing the torque of reference motor, finite element analysis method (FEM) is used by MAXWELL software. Simulation result shows that in nominal speed, Torque of reference motor swings between -216 to +216 mNewton-meters. Torque ripple of the reference motor is shown in Fig. 4.

4. COGGING TORQUE CANCELATION WITH NEW SHAPE OF PMS

As it is shown in literatures, shape of permanent magnet has an important impact on cogging torque of PM machines. In this paper,

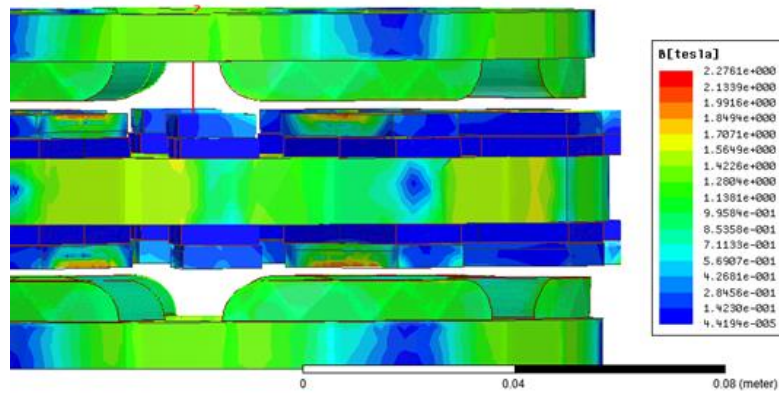

Fig. 7. Electromagnetic analysis of improved motor, SIDE.

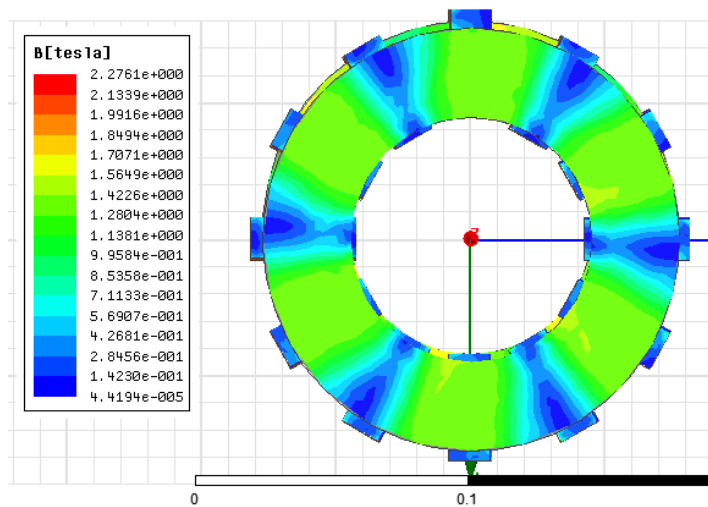

Fig. 8. Electromagnetic analysis of improved motor, UP.

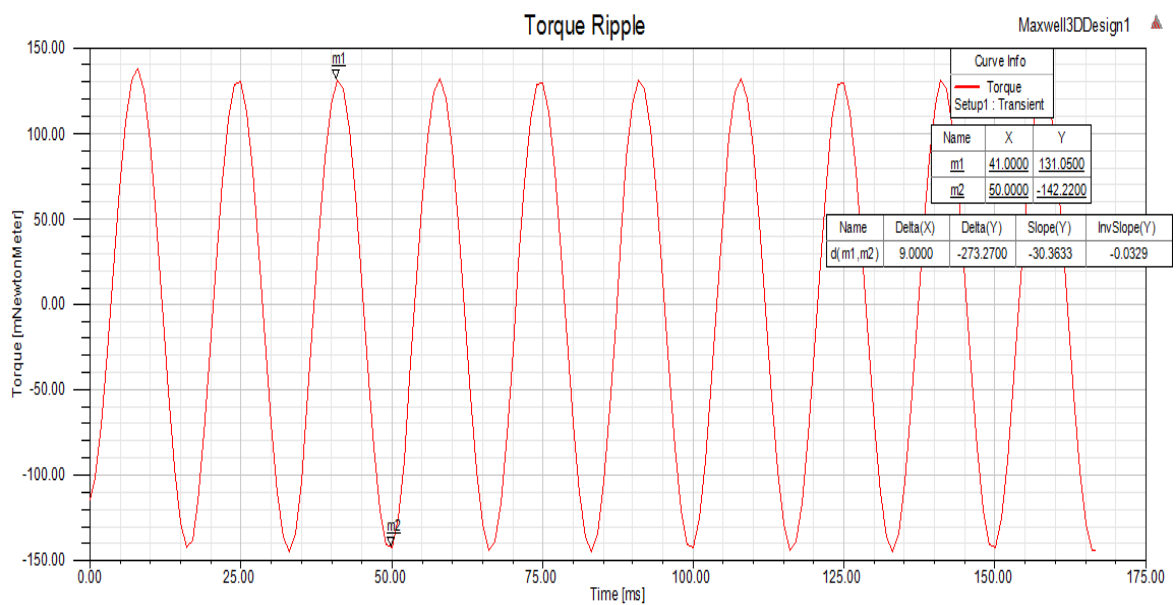

Fig. 9. Torque ripple of improved motor.

skewed permanent magnets are improved by rounding their edges as shown in Fig. 5. This new shape is in fact, combination of two methods of cogging torque cancelation.

Fig. 6 shows one stator of improved motor. Electromagnetic analysis of the motor is also shown in Figs. 7 and 8. As there is no change in reference motor and improved one, change in torque ripple is just because of permanent magnets shape. Fig. 9 shows the torque ripple of the improved motor.

Electromagnetic analysis shows, no problem in flux distribution of the motor and there is no sign of saturation in cores even in stator teeth. Result of torque analysis of improved motor indicates that torque ripple swings between -142 to +142 mNewton-meters. This result means torque of this motor is 0.644 of reference motor's torque ripple which means 35.6 percent reduction of torque ripple. This reduction is because of round sides of PMs which make air gap energy changes smoothly.

5. CONSLUSION

In this paper, a new shape for permanent magnets of an axial flux permanent magnet motor which is designed for hybrid vehicle application is proposed. Reference motor is an AFPM SM with TORUS topology which has skewed shape PMs. It is shown by FEM analysis that with new shape, the cogging torque is reduced by 35.6 percent compared with reference motor. Also, the electromagnetic analysis shows that there is no magnetic difficulty.

REFERENCES

- [1] Nihat Ozturk, Adem Dalcali, Emre Celik, Selcuk Sakar, "Cogging torque reduction by optimal design of PM synchronous generator for wind turbines", international journal of hydrogen energy, Vol. 42 – 2017.
- [2] Joya C. Kappatou, Georgios D. Zalokostas, Dimitrios A. Spyrtos, "3-D FEM Analysis, Prototyping and Tests of an Axial Flux Permanent-Magnet Wind Generator", *Energies Journal*, Volume 10, Issue 9- 2017.
- [3] M.Aydin, S.Huang, T.A.Lipo, "Axial Flux Permanent Magnet Disc Machines: A Review", Research Report, Wisconsin-Madison University, January 2004.
- [4] M.Aydin, Z.Q.Zhu, T.A.Lipo, "Minimization of cogging torque in axial flux permanent –magnet machines: Design Concepts", *IEEE transactions on magnetics-Vol.43-No.9* –September 2007
- [5] M.Aydin, S.Huang, T.A.Lipo, "Optimum Design and 3D Finite Element Analysis of Non-Slotted and Slotted Internal Rotor Type Axial Flux PM Disc Machines", *Power Engineering Society Summer Meeting. Conference Proceedings*, 2001.
- [6] Chang-Shou Huwang, et. al., "Optimization for reduction of torque ripple in an axial flux permanent magnet machine", *IEEE Transactions on Magnetics*, Vol. 45, No. 3, march 2009
- [7] D.A.Gonzales, J.A.Tapia, A.L.Bettancourt, "Design Consideration to Reduce Cogging Torque in Axial Flux Permanent-Magnet Machines", *IEEE Transactions on Magnetics*, Vol. 43, Issue 8, Aug. 2007.
- [8] Praveen Kumar, R. K. Srivastava, "Cost-Effective Stator Modification Techniques for Cogging Torque Reduction in Axial Flux Permanent Magnet Machines", *IEEE Transportation Electrification Conference and Expo, Asia-Pacific (ITEC Asia-Pacific)*, June 2018.

-
- [9] Vicente Simón-Sempere, Manuel Burgos-Payán¹, José-Ramón Cerquides-Bueno, “Cogging Torque Cancellation by Magnet Shaping in Surface-Mounted Permanent-Magnet Motors”, IEEE Transactions on Magnetics, Vol. 53, Issue 7, July 2017.
 - [10] Hamed Farnaghizad, Hamid Lesani, “Optimal Design of an Axial Flux PMSM for Hybrid Vehicle Use”, Signal Processing and Renewable Energy Journal, Volume 2, Issue 2, June 2018.