



Sliding mode controller design for DC-DC Quasi-Z-source converter

Navid Vahidfar¹, Mohammad Hosein Ershadi^{1*}

¹Department of Electrical Engineering, Khomeinishahr Branch, Islamic Azad University

Abstract

The main purpose of this research is designing the sliding mode controller for a Quasi-Z-source converter. For this purpose, we first introduce a Quasi-Z-source converter. These converters, similar to the source Z (ZSC) exchangers, are composed of connecting an impedance network to a voltage and a current source. The advantages of comparing the Quasi-Z-source converter with Z source converters are: installing input flow (in the source type voltage), reducing nominal values for I, V circuit (inductance and capacitor), and generating high voltage gain. These advantages have led to use these converters in photovoltaic applications, wind turbines and hybrid electric vehicles. The Quasi-Z-source converter is extracted from the transducer's moderate model and accordingly, the slider mode controller is designed. Finally, the results resembled the accuracy of the controller function for the converter is shown for two different duty cycles.

Keywords: DC-DC converter, quasi-source Z, moderated model.

1. INTRODUCTION

In electronic systems, power supplies are used to provide dc voltage from the city's ac voltage. In general, power supplies are of two types: A) Linear power supply and B) nonlinear power supply (switching). The rapid advances in electronics in recent years require a thriving development of these resources as well in order to reduce weight and increase efficiency. This is assumed that the density of the power ratio to volume, without a significant reduction in efficiency, remains at a high level. For this purpose, a brief acquaintance with linear resources is given. It will be shown that for reasons of low volume and high efficiency, be found. Then the frequency switching power supplies are introduced as the only proposed solution. We need to know that this category of resources is much more complex than the linear

one. Because one needs an extensive knowledge of designing analogue electronic circuits, and magnetic devices like control circuits and logic. In the switching power supply, more storage time is required than linear power supplies. This is because of the high voltage dc stored in the input capacitor. Since the stored energy in the capacitor is related to the voltage squared, the switching source needs more storage time.

In general, power converters are grouped into (1) FlyBack, (2) Buck, and (3) Buck-drive. The structure of the flyback type converters is such that the output voltage can be greater or less than the input voltage (acting as a dimming or augmentative). But tank and bucket-drive converters usually act as dimming devices. In Buck-Drive convertors (such as coveralls, half-bridges, and bridge terminals), since the proper combination of two forward convertors is used, the output

*Corresponding Author's Email: ershadi@iaukhsh.ac.ir

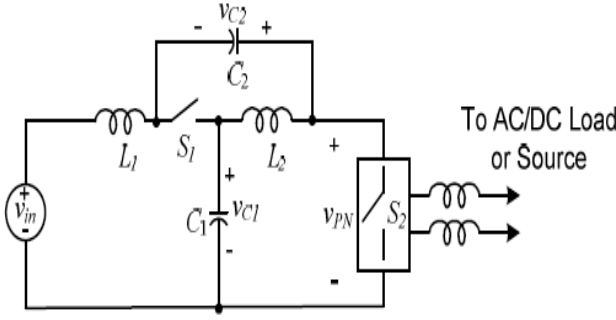

Fig. 1. The Quasi-Z-source converter is shown.

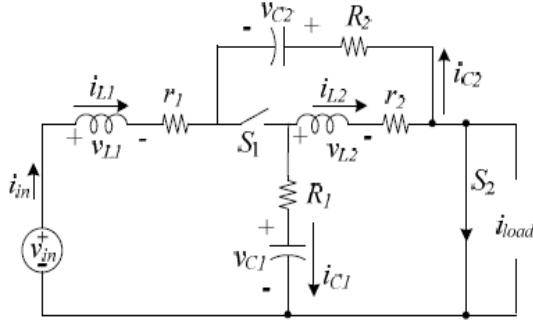

Fig. 2. The first state circuit.

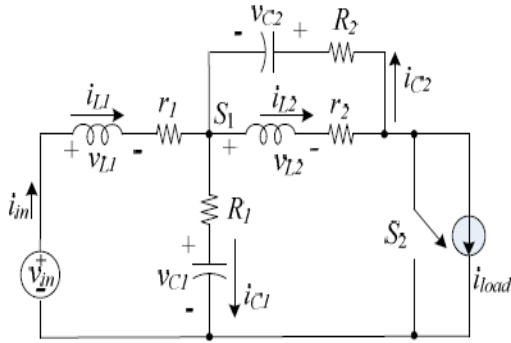

Fig. 3. The second state circuit.

power is higher than the two previous ones, which is why it is called a buck converter [1].

2. INTRODUCING THE DC-DC QUASI-Z-SOURCE CONVERTER

The idea of the Quasi-Z-source converter (qzsc) was first introduced in 2007. These converters, like the Z-Z source (ZSC) converter, are composed of connecting an impedance network to a voltage and current source. The main advantages of Quasi-Z-source converter in comparison with Z source converters are [2]:

- Installation of input current (in type of voltage source).

- Reducing nominal values (I, V circuit (inductor and capacitor)).
- Generate high voltage gain.

These advantages have led to the use of these converters in photovoltaic applications, wind turbines and hybrid electric vehicles. Figure 1 shows the Quasi-Z-source converter [3].

The Quasi-Z-source converter circuit has two functional states that explained in following. First Situation Analysis where the S1 switch is disconnected and the S2 switch is connected, see Figure 2.

For the first state circuit, the following orbital relations can be written:

$$V_{L1} = L_1 \frac{di_{L1}}{dt} = V_{in} + V_{C2} - (r_1 + R_2)i_{L1} \quad (1)$$

$$V_{L2} = L_2 \frac{di_{L2}}{dt} = V_{C1} - (r_2 + R_1)i_{L2} \quad (2)$$

$$i_{C1} = c_1 \frac{dV_{C1}}{dt} = -i_{L2} \quad (3)$$

$$i_{C2} = c_2 \frac{dV_{C2}}{dt} = -i_{L1} \quad (4)$$

Second Situation Analysis where the switch S1 is plugged in and the S2 switch is disconnected, see Figure 3.

For the second state circuit, the following circuit equations can be written:

$$V_{L1} = L_1 \frac{di_{L1}}{dt} = V_{in} + V_{C1} - r_1 i_{L1} - R_1 i_{C1} \quad (5)$$

$$V_{L2} = L_2 \frac{di_{L2}}{dt} = -V_{C2} - r_2 i_{L2} - R_2 i_{C2} \quad (6)$$

$$i_{C1} = c_1 \frac{dV_{C1}}{dt} = i_{L1} - i_{L2} + i_{C2} \quad (7)$$

$$i_{C2} = c_2 \frac{dV_{C2}}{dt} = i_{C1} + i_{L2} - i_{L1} \quad (8)$$

$$i_{C2} = i_{L2} - i_{Load} \quad (9)$$

3. EXTRACTING EQUATIONS OF STATE SPACE MODEL

For this purpose, first, state space variables are defined as follows:

$$X = [x_1 \ x_2 \ x_3 \ x_4]^T = [i_{L1} \ i_{L2} \ V_{C1} \ V_{C2}]^T \quad (10)$$

Now the equations for the first state, i.e Eqs. (1)-(4), can be written in matrix form as,

$$\frac{dx}{dt} = A_1 X + B_1 U \quad (11)$$

Also, equations for the second state, i.e. Eqs. (5)- (9), can be written in matrix form as,

$$\frac{dx}{dt} = A_2 X + B_2 U \quad (12)$$

where, the used variables in Eqs. (11)- (12) are defined in following,

$$U = [i_{load} \quad V_{in}]^T \quad (13)$$

$$A_1 = \begin{bmatrix} \frac{-(r+R)}{L} & 0 & 0 & \frac{1}{L} \\ 0 & \frac{-(r+R)}{L} & \frac{1}{L} & 0 \\ 0 & \frac{-1}{c} & 0 & 0 \\ \frac{-1}{c} & 0 & 0 & 0 \end{bmatrix} \quad (14)$$

$$B_1 = \begin{bmatrix} 0 & 0 & 0 & 0 \\ \frac{1}{L} & 0 & 0 & 0 \end{bmatrix}^T \quad (15)$$

$$A_2 = \begin{bmatrix} \frac{-(r+R)}{L} & 0 & \frac{-1}{L} & 0 \\ 0 & \frac{-(r+R)}{L} & \frac{1}{L} & \frac{-1}{L} \\ \frac{1}{c} & 0 & 0 & 0 \\ 0 & \frac{1}{c} & 0 & 0 \end{bmatrix} \quad (16)$$

$$B_2 = \begin{bmatrix} \frac{R}{L} & \frac{R}{L} & \frac{-1}{c} & \frac{-1}{c} \\ \frac{1}{L} & \frac{1}{L} & 0 & 0 \end{bmatrix}^T \quad (17)$$

Now, if we define the duty cycle of the S2 switch D, the state-mediated state model for this converter is,

$$\frac{dx}{dt} = AX + BU \quad (18)$$

where,

$$A = DA_1 + (1 - D)A_2 \quad (19)$$

$$B = DB_1 + (1 - D)B_2 \quad (20)$$

4. CALCULATE THE OUTPUT VOLTAGE RELATIONSHIP

For this purpose, and for simplicity of calculation, the internal resistance of the inductors and capacitors is ignored. Now, for computing the output voltage, it is necessary to write the balance of seconds for the L1, L2 inductors. According to the relations (1) and (5), the inductor L1 in the time interval 0 to DT, which is connected to the S2 switch, is $V_{in} + V_{c2}$ and is equal to $V_{in} + V_{c1}$ at the time interval DT to T, the switch S2 is disconnected. So, the balance of the second L1's delay is,

$$V_{L1} = (V_{in} + V_{c2})DT + (V_{in} + V_{c1})(1 - D)T = 0 \quad (21)$$

According to the relations (2) and (6), the inductance voltage L2 at the time interval 0 to DT, the switch S2 is connected, is equal to V_{c1} and is

equal to $-V_{c2}$ at the time interval DT to T, the switch S2 is disconnected. Then, the balance of the second L2 inductance is,

$$V_{L2} = (V_{c1})DT + (-V_{c2})(1 - D)T = 0 \quad (22)$$

It can now be concluded from the relations (21) and (22):

$$V_{c1} = \frac{1-D}{1-2D} V_{in} \quad (23)$$

$$V_{c2} = \frac{D}{1-2D} V_{in} \quad (24)$$

The output voltage will now be as follows:

$$V_o = V_{c1} + V_{c2} = \frac{1}{1-2D} V_{in} \quad (25)$$

5. SLIDE MODE CONTROLLER DESIGN

To design the slide mode controller for the desired converter, we need to find the state space equation obtained for the converter in the form below [4],

$$\dot{X} = f(x) + g(x)u \quad (26)$$

$$y = h(x) \quad (27)$$

where $u = D$, and $g(x)$ are variables with coefficients D and $f(x)$ are variables that do not have coefficients D. Using the obtained state space equations, the matrices $f(x)$ and $g(x)$ are given as follows:

$$f(X) = \begin{bmatrix} 0 & 0 & \frac{(x_1+x_2)V_{in}}{L_1} & \frac{c_1(x_4+x_3)}{L_1} \end{bmatrix}^T \quad (28)$$

$$g(X) = \begin{bmatrix} 0 & 0 & 0 & \frac{c_2(x_4+L_1x_1)}{L_2} \end{bmatrix}^T \quad (29)$$

First, we want to see if there is a possibility of direct control of the output voltage, so we set $x_4 = v_o$ for this purpose, that is, the proposed slider is the output voltage, which we will have:

$$y(x)=h(x)=x_4 - v_{ref} \quad (30)$$

In this case we will have:

$$\frac{\partial h}{\partial x^T} = \begin{bmatrix} \frac{\partial h}{\partial x_1} & \frac{\partial h}{\partial x_2} & \frac{\partial h}{\partial x_3} & \frac{\partial h}{\partial x_4} \end{bmatrix} = [0 \quad 0 \quad 0 \quad 1] \quad (31)$$

We show the derivative $h(x)$ in the direction $f(x)$ as the scalar quantity $\frac{\partial h}{\partial x} \cdot f(x)$ and we define it as $L_f h(x)$ [5],

$$\frac{\partial h}{\partial x^T} f(x) = L_f h(x) = [0 \quad 0 \quad 0 \quad 1] f(x) = \frac{c_1(x_4+x_3)}{L_1} \quad (32)$$

We show the derivative $h(x)$ in the direction $g(x)$ as the scalar quantity $\partial h / (\partial x \wedge T) g(x)$ and we define it as $L_g h(x)$.

$$\frac{\partial h}{\partial x^T} g(x) = L_g h(x) = [0 \ 0 \ 0 \ 1]g(x) = \frac{C_2(x_4 + L_2 x_2)}{L_2} \quad (33)$$

By dividing the derivative $h(x)$ in the direction $f(x)$ on the derivative $h(x)$ in the direction $g(x)$ we will call u_{eq} :

$$u_{eq} = -\frac{L_f h(x)}{L_g h(x)} = -\frac{\frac{\eta C_1(x_4 + x_2)}{L_1}}{\frac{C_2(x_4 + L_2 x_2)}{L_2}} \quad (34)$$

Now, to show the stability of the system, we consider the energy function of the system (the Lyapunov function) as follows:

$$V(X) = \frac{1}{2} L_1 X_1^2 + \frac{1}{2} L_2 X_2^2 + \frac{1}{2} C_1 X_3^2 + \frac{1}{2} C_2 X_4^2 \quad (35)$$

The derivative of the above function, Eq. (35), is as follows:

$$\dot{V}(X) = L_1 \dot{X}_1 X_1 + L_2 \dot{X}_2 X_2 + C_1 \dot{X}_3 X_3 + C_2 \dot{X}_4 X_4 \quad (36)$$

Now, if in the above-derived equation we replace the state variables from the state equations of the system, namely, relation (18) and use the relation (34) instead of the parameter D :

$$\dot{V}(X) = -L_1 \left(C_1 X_1 + C_2 X_2 + \frac{V_{in}}{L_1} \right)^2 \quad (37)$$

Due to the negative derivation of the Lyapunov function, the stability of the system is proven in the control of the output voltage [6].

6. SIMULATION RESULTS

The simulation results of Slide Mode control for a DC-DC converter with a Z-source are given in following where the following simulation parameters are used:

- Vin= 130 (V)
- L1=L2=500 (uH)
- C1= 100 (uF)
- C2=100(uF)
- R=8 (ohm)
- F=20 (KHz)

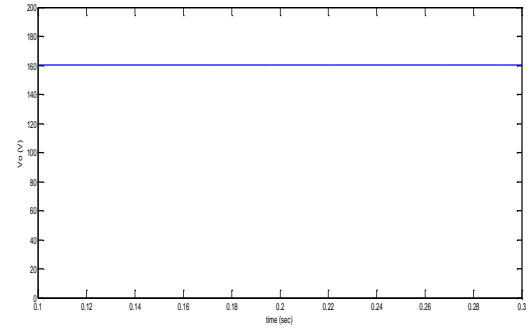

Fig. 4. The output voltage converter is shown.

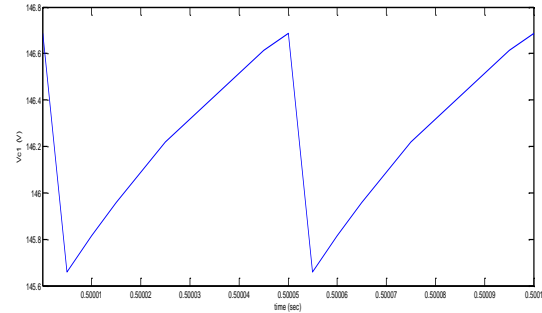

Fig. 5. Capacitor voltage C1.

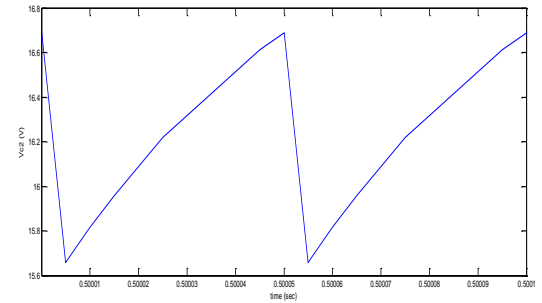

Fig. 6. Capacitor voltage C2.

5.1. Simulation Results for Reference Voltage of 160 V

In this simulation, the reference voltage of 160 volts is applied to the control system to indicate the correct operation of the controller. Figure 4 shows the output voltage of the converter.

As seen in Figure 4, the output voltage is about 160 volts and has been able to track the reference value. In this situation, the voltage waveform of the C1 capacitor is illustrated in Figure 5.

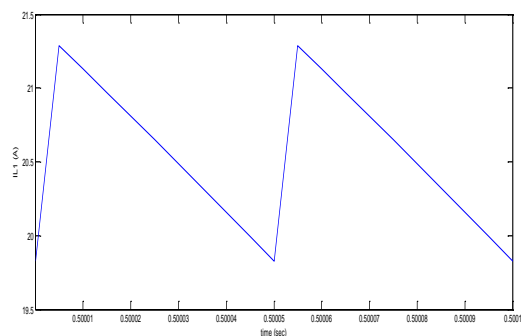

Fig. 7. The inductor current $L1$.

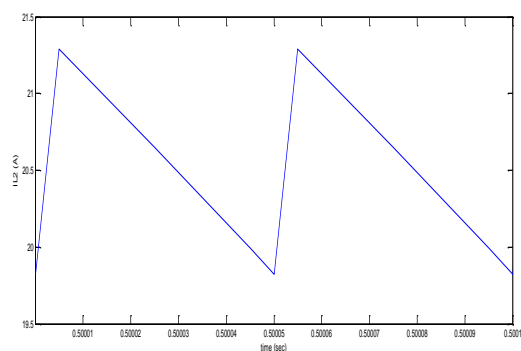

Fig. 8. $L2$ inductor current.

As shown in Figure 5, the capacitor $C1$ voltage is about 146 volts, which corresponds to the relationship between the capacitor $C1$ achieved in Section 3. In this situation, the voltage waveform of the capacitor $C2$ is sketched in Figure 6.

As shown in Figure 6, the voltage of the capacitor $C2$ is about 16 volts, which corresponds to the relationship of the capacitor voltage $C2$ obtained in Section 3. In this situation, the shape of the inductor $L1$ is shown in Figure 7.

As shown, the inductor $L1$ value is about 21 amps. In this situation, the shape of the $L2$ inductor is shown in Figure 8.

In which, the $L2$ inductor is about 21 amps.

5.2. Simulation Results for 220 V Reference Voltage

In this simulation, the 220 V reference voltage has been applied to the control system in order to indicate the correct operation of the control system. Figure 9 shows the output voltage of the converter.

As shown in Figure 9, the output voltage is

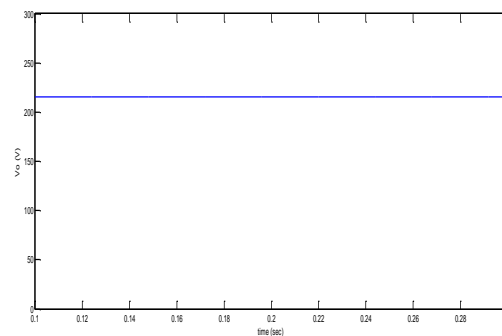

Fig. 9. The output voltage of the converter.

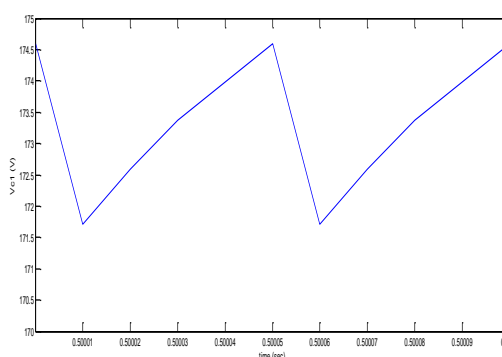

Fig. 10. Capacitor voltage $C1$.

about 220 volts which has been able to track the reference value as well. In this situation, the voltage waveform of the $C1$ capacitor is seen in Figure 10.

Where, the capacitor $C1$ voltage is about 175 volts, which corresponds to the voltage $C1$ ratio obtained in Section 3. In this situation, the voltage waveform of the capacitor $C2$ is sketched in Figure 11.

As shown in this figure, the voltage of the capacitor $C2$ is about 44 volts, which corresponds to the relationship of the capacitor voltage $C2$ obtained in Section 3. In this situation, the shape of the inductor $L1$ is illustrated in Figure 12.

As shown in Figure 12, the inductor $L1$ is about 28 amps. In this situation, the shape of the $L2$ inductor is shown in Figure 13. Where the $L2$ inductor current is about 28 amps.

6. CONCLUSION

The main purpose of this paper is to design a slide mode controller for a Quasi-Z-source converter. For this purpose, the Quasi-Z-source converter is investigated. These converters are simi-

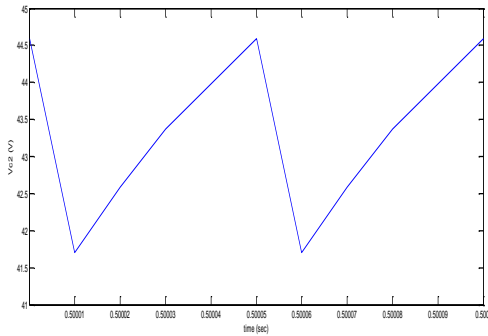

Fig. 11. Capacitor voltage C2.

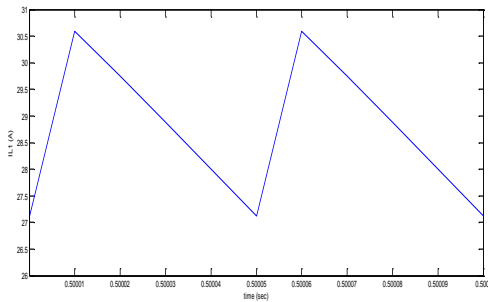

Fig. 12. L1 inductor current.

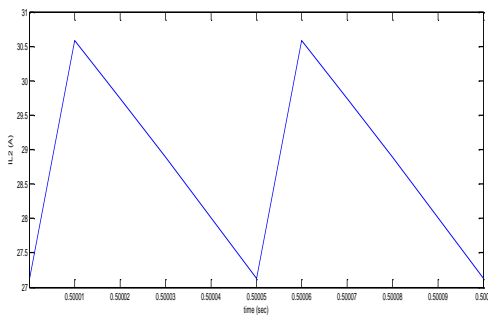

Fig. 13. L2 inductor current.

lar to those of the source Z (ZSC) converter from the connection of an impedance network to a voltage and current source. The advantages of quasi-source converters Z in comparison with Z source converters are:

- Installation of input current (in type of voltage source).
- Reducing nominal values for I, V circuit (inductor and capacitor).
- Generate high voltage gain.

These advantages have led to the use of these converters in photovoltaic applications, wind turbines and hybrid electric vehicles. After introducing DC-DC Quasi-Z-source converter, the moderated converter model was extracted based on

designing the slide mode controller. Finally, the simulation results show the correctness of the controller's performance for the converter for two values of the reference voltage.

REFERENCES

- [1] j. anderson and F.Z. peng, "Four Quasi-Z-source Inverters," in proc. IEEE PESC'08, pp.2749, 2008.
- [2] F.Z. Peng, "Z-Source Inverter," IEEE Trans on Ind. Appl., vol. 39, No. 2 , pp .504-510March/April, 2003.
- [3] Y .Li, j. Anderson and F.Z. Peng and D. C. Liu, "Quasi-Z-source inverter for photovoltaic power generation systems, " in proc. 24th IEEE APEC'09, pp. 918-924, 2009.
- [4] Y. S. Liu, B. M. Ge, F.Z. Peng, A. R. Haitham, A. T. de Almeida and F. J.T. E. Ferreira, "Quasi-Z-Source inverter based PMSG wind power generation system," in proc. Of IEEE ECCE, Sept.17-22,pp.291-297, 2011.
- [5] S. T. Yang, F.Z. Peng, Q. Lei, R. Inoshita and Z. M. Qian, "Current-fed quasi-Z-source inverter with voltage buck-boost and regeneration capability," IEEE Trans. on Ind., Appl., vol. 47, no. 3, pp. 882-892, March/April, 2011.
- [6] F. Z. Peng, M. Shen, and Z. Qian, "Maximum boost control of the Z source inverter," IEEE Trans. Power electron, vol.5, no.4, pp.438-445, 2014.