

## **Taper Design of Vivaldi Antenna by Butterworth Method**

**Mahdi Ghoorchian<sup>1</sup>, Nasrin Amiri<sup>2\*</sup>**

<sup>1,2</sup>Electrical Engineering Department, South Tehran Branch, Islamic Azad University, Tehran, Iran.

### **Abstract**

In this paper a method to design tapered slot antenna (TSA), a member of ultra-wideband (UWB) antenna, is presented. The proposed method is related to impedance matching of input and free space intrinsic impedance by Butterworth method. By this method, curve fitting converts step impedance to optimized curve and this optimized curve and its symmetry create Vivaldi antenna. The fractional bandwidth (FBW) of the antenna by the proposed method is 155% which is more than the methods of Chebyshev and attenuation. A prototype of this antenna is fabricated and simulation and measurement results are in good agreement.

**Keywords:** Tapered slot antenna, Ultra wide band, Curve fitting, Vivaldi antenna.

### **1. INTRODUCTION**

The UWB antennas are the special part of modern communication systems. One of them is Vivaldi antenna by fractional bandwidth (FBW) more than 80%. Step impedance is the base to design this antenna. Chebyshev [1-2] and power flow and attenuation [3] methods are proposed before to design these steps.

In Chebyshev and power flow and attenuation methods, the created step impedance will be optimized to a curve as the radiation flare. Ebnabbasi and et al [1-2] used Chebyshev method to find steps of slot line and design impedance matching. The Width of each slot is determined by Chebyshev method and finally curve fitting helps to create optimized curve of flare. This is a prevalent method to design the UWB structures. The FBW of TSA in [1] is 143%. Oraizi and Jam use the power flow and attenuation and the minimization procedure gives the slotline widths

and lengths [3]. This method is precise but calculations are very long and complicated and the FBW is 85%. In this paper, Butterworth method is used to find the width of each step which would be increased gradually to make the impedance of final step bigger than the free space intrinsic impedance. Then these steps are converted to an optimized curve and finally with two smooth and symmetric curves the Vivaldi antenna is created. The formulas of this method are not complicated and calculations are very easy also the FBW is more than that two other methods.

In continue, the design procedure will be discussed. The fractional bandwidth of three methods and also the results of simulation and measurements of the fabricated antenna will be shown.

### **2. ANTENNA DESIGN**

Fig.1 shows a step slot line that is the base of Vivaldi antenna design. This model is a sample of N section quarter wave transformer that matches load impedance (ZL) to input impedance (Z0).

---

\*Corresponding Author's Email: n\_amiri@azad.ac.ir

Characteristic impedance of each section can be calculated by the following equation [4]:

$$Z_{ok} = Z_o \left( \frac{R_L}{Z_o} \right)^{M_k / 2^N} \quad (1)$$

$$k = 1, 2, \dots, N$$

$M_k$  is related to binomial expansion coefficient:

$$M_k = C_1 + C_2 + C_3 + \dots + C_k \quad (2)$$

$$C_n = \frac{N!}{(N-n+1)! (n-1)!} \quad (3)$$

$$n = 1, 2, 3, \dots, N$$

In Fig.1, the number of steps in step slot line is calculated by (4) [1]:

$$N = 4(L - L_{S1}) / \lambda_s \quad (4)$$

Where  $\lambda_s$  is the slot line guide wavelength at the center frequency which is calculated in [2-5].  $L_{S1}$  is set to one quarter of the free space wavelength  $\lambda_0$ . The length ( $L$ ) and width ( $W$ ) of the antenna are respectively  $\lambda_0$  and  $\lambda_0/2$  at minimum frequency. The length of each step ( $L_i$ ) is  $\lambda_s/4$  [1]. Equation (1) and formulas of [5] are used to calculate the width of each step in MATLAB.

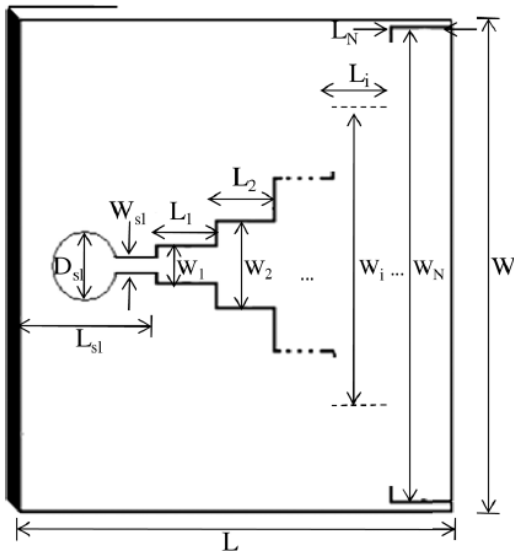

Fig. 1. A model of step slot line [1].

In this paper, the frequency is 1-3GHz and substrate is RO4003 with dielectric constant of 3.55. Input slot line impedance is  $Z_o=84\Omega$ . Output impedance is  $Z_L=k\eta_0$  ( $\eta_0$  is free space intrinsic impedance). But  $k$  should be chosen such that the maximum slot width  $W$  is more than  $\lambda_0/2$  that creates appropriate coupling between input slotline and free space [2]. Letting  $k=1.12$  and  $N=10$ . The width of each step is calculated by Butterworth method and shown in Table 1. The other dimensions of step line structure are listed in Table 2.

Now by curve fitting toolbox of MATLAB, step slots are converted to an optimized curve. Curve fitting takes the end point of each step as input and gives some optimized curves as output. In this paper exponential curve is selected as the optimized curve. The coefficients of exponential function ( $y = a \times e^{bx}$ ) are  $a=0.8007$  and  $b=0.02538$ . Fig.2 shows the end point of each step and the exponential curve created by these points.

Fig.2 shows the half of the structure. By symmetrizing this curve in the direction of length, complete flare shape of the antenna will be created. The distance between the curves should be equal to the width of slot that has the same impedance with input impedance ( $Z_0$ ). Which is  $W_{s1} = 0.32\text{mm}$ .

Fig.3 shows the antenna by step structure created by Butterworth method and the Vivaldi antenna created by exponential curve.

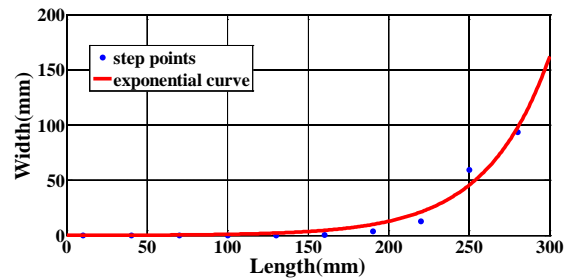

Fig. 2. Exponential curve is created by the end point of each step impedance.

**Table 1. Width of step slot lines.**

N	W(mm)	
1	$W_{S1}$	0.32
2	$W_1$	0.33
3	$W_2$	0.34
4	$W_3$	0.4
5	$W_4$	0.65
6	$W_5$	1.5
7	$W_6$	8
8	$W_7$	26
9	$W_8$	119
10	$W_9$	188

**Table 2. Dimension of step impedance structure.**

L	307mm
W	195mm
$L_i$ $i=1,2,\dots,10$	30mm
$D_{S1}$	16mm

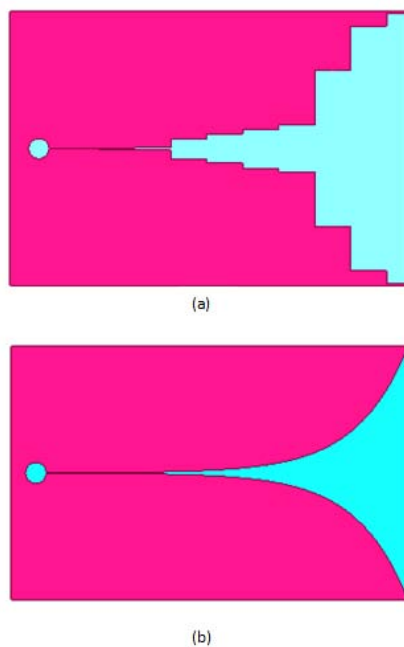

**Fig. 3 (a) Step impedance by Butterworth method  
(b) Vivaldi antenna by exponential curve.**

### 3. RESULT AND DISCUSSION

The designed structure is simulated by HFSS. This antenna is fabricated by RO4003 as substrate and is shown in Fig.4. As it is shown in the Fig.4.b, feed line is a microstrip step line that matches input port with input of slot line. Impedance of each step is 50, 61.5, 75.56 ohm.

Comparisons between simulation and measurement for Return Loss are shown in Fig.5 in good agreement.

As illustrated in Fig.5 the return loss is lower than -10 in 0.5-4 GHz. As the figure show, the antenna creates a good impedance matching between input and free space. Fractional bandwidth for this structure is 155%. Table 3 shows comparison of fractional bandwidth for three methods of Butterworth, Chebyshev [1-2] and power flow and attenuation [3].

Radiation patterns of co-polarization and cross-polarization are shown in Fig.6. Pattern of co-polar shows acceptable result while cross-polar is not good enough which can improve by antipodal method as the feed.

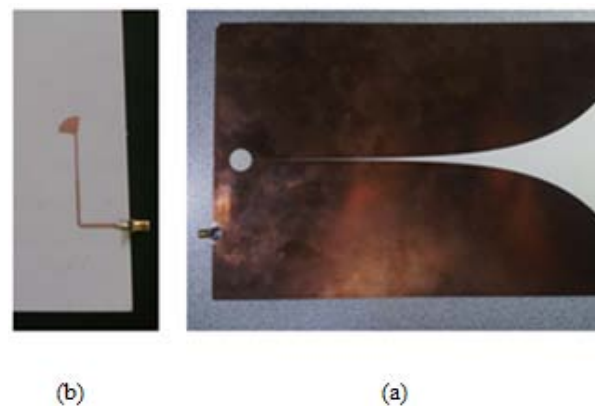

**Fig. 4 (a) Fabricated Vivaldi antenna by Butterworth method (b) Feed line of antenna.**

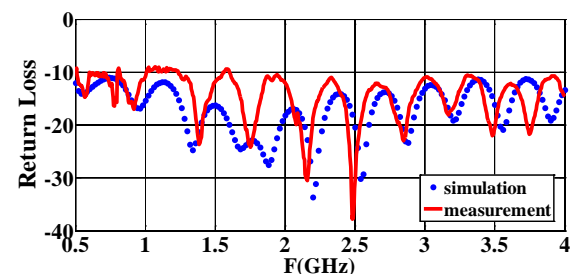

**Fig. 5 Comparison between simulation and measurement for Return Loss.**

**Table 3. FBW of three methods to design of Vivaldi antenna**

Method Of Design	Fractional Bandwidth (%)
Butterworth	155
Chebyshev [1-2]	143
Power flow and attenuation [3]	85

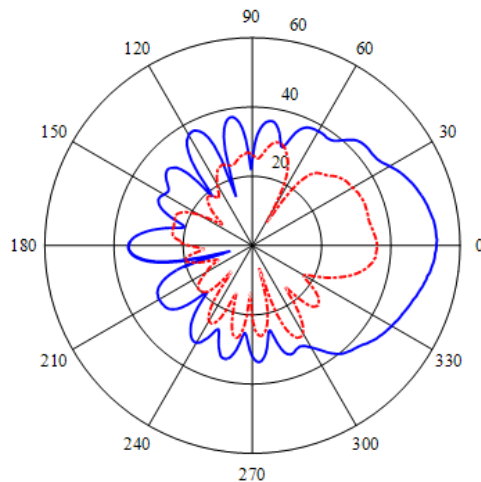

**Fig. 6** E-plane co-polar and cross-polar radiation pattern in frequency of 3GHz.

#### 4. CONCLUSION

Butterworth as a method with simple calculation is introduced to calculate the width of slots in step impedance model to design Vivaldi antenna. Then step slots are converted to exponential curve. Fractional bandwidth of the fabricated antenna is 155% which is more than Chebyshev and power flow and attenuation's FBW.

#### ACKNOWLEDGMENT

We would like to thank Dr. Mohsen Kaboli and Maryam Aghakhani for their advice.

#### REFERENCES

[1] Khabat Ebnabbasi, Dan Busuioc, Ralf Birken, and Ming Wang," Taper Design of Vivaldi and Co-Planar Tapered Slot Antenna (TSA) by Chebyshev Transformer," IEEE Trans. Antennas Propagat. ,vol. 60, NO. 5, May 2012.

- [2] Khabat Ebnabbasi and Heinrich D. Foltz," Vivaldi Antenna Taper Design Based on Impedance Matching," IEEE Antennas and Propagation Society International Symposium, 2008
- [3] Homayoon Oraizi, Senior Member and Shahrokh Jam," Optimum Design of Tapered Slot Antenna Profile IEEE Trans. Antennas Propagat., vol. 51, NO. 8, August 2003.
- [4] Peter A. Rizzi," Microwave Engineering: Passive Circuits", 1st ed, Prentice Hall, 1988
- [5] Ramesh Garg, Inder Bahl, Maurizio Bozzi," Microstrip Lines and Slotlines", 3rd ed, Artech House, 2013
- [6] Gaurav Dwivedi," An Ultra Wideband Wide Beam Strip line Fed Taper Slot Antenna for Active Phased Array Jammer", International Journal of Engineering and Advanced Technology (IJEAT), vol-1, Issue-6, August 2012.
- [7] Amin M. Abbosh," Miniaturized Microstrip-Fed Tapered-Slot Antenna With Ultrawideband Performance", IEEE Antennas and Wireless Propagation Letters, vol. 8, 2009.